

LYRA T6 ALUMINIUM PERGOLA (SPLIT INTO TWO BAYS) INSTALLATION INSTRUCTION

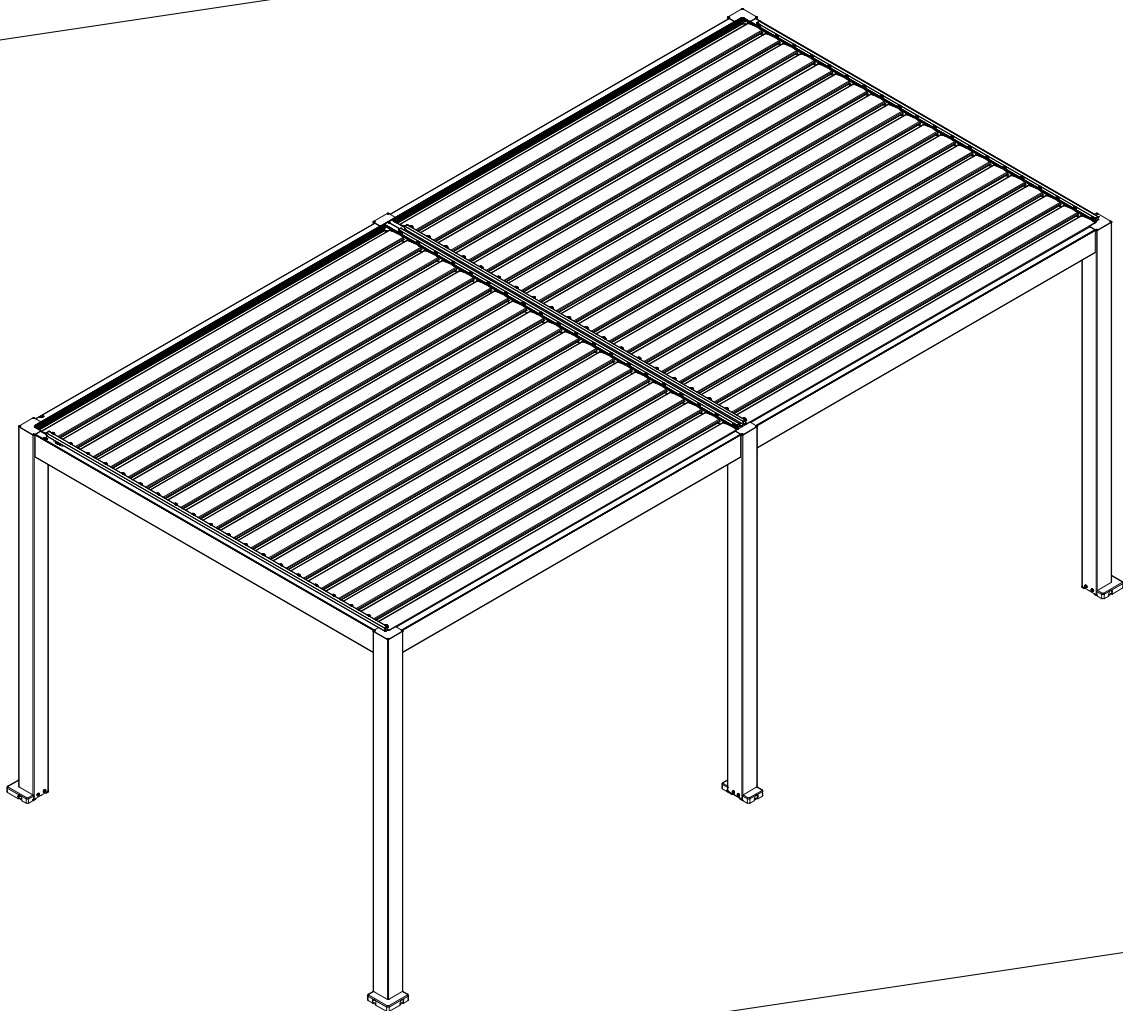

STATEMENTS

Please read the following carefully before installation:

1. This is a general version of the installation manual. Please make sure to review the design drawings when placing your order and read this manual several times before beginning to assemble the louver pergola. The installation steps can be referred to this manual, but other specific details, such as motor position, drainage direction, etc., should be based on the design drawings of the order placed.
2. Check the parts list, don't throw away any packaging until you are sure you have all the parts.
3. Installation requires at least 3 people.
4. It is highly recommended that you fix the pergola to a concrete floor to provide maximum stability
5. It needs 2 people to take the product parts out from the package ,please put the product very gentle ,it is better to cover a carpet or hard paper box on the floor to protect it from scratching
6. Don't drag the goods on the ground to avoid the profile collision with other obstacles causing damage.
7. The plastic packaging film on the surface of the product should be removed after the installation process immediately .It is not easy to remove under extremely weathers exposed .
8. Please do not DIY our product and take use of the other alternative accessories when you change the original design ,that will void your warranty
9. We hold no responsibility for any damage caused due to human factor ,especially incorrect assembly.
10. During the installation process, if you encounter any uncertainties, please refer to the installation instructions on the product page of the website.

Please refer to the 2D view drawing of the product before installing it, and then follow the installation steps in this installation manual



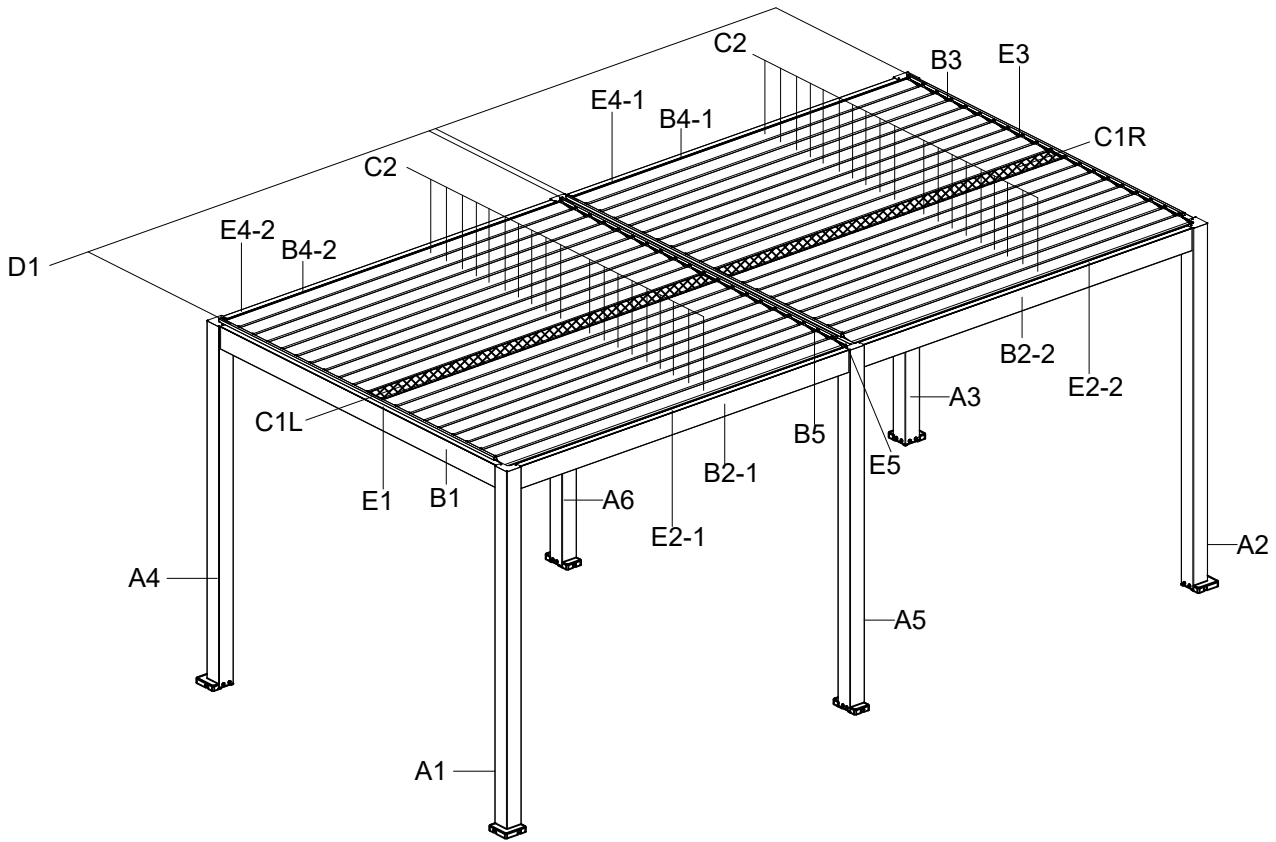























Components



code	name	section	photo
A1	post		
A2	post		
A3	post		
A4	post		
A5	post		
A6	post		
B1	beam & gutter		
B2-1	beam & gutter		
B2-2	beam & gutter		
B-3	beam & gutter + motor		
B4-1	beam & gutter		
B4-2	beam & gutter		
B5	beam & gutter		

code	name	section	photo
C1L	driven louver left		
C1R	driven louver right		
C2	louver		
D1	connection bar		
E1	beam flashing		
E2-1	beam flashing		
E2-2	beam flashing		
E3	beam flashing		
E4-1	beam flashing		
E4-2	beam flashing		
E5	beam flashing		

Hardware

code	name	photo	remarks
1-3	base plate		
1-5	base plate		
2-6	base plate cover		
2-7	base plate cover		
3-3	post top cover		
3-4	post top cover		
4-11	driven louver cap(right)		
4-12	driven louver cap(left)		
5-1	louver pivot cap		
6-1	gutter corner inset bar		
6-2	gutter decoration casing (left)		
6-3	gutter decoration casing (right)		
7-3	transformer (control system0(single motor+led light)		packed in the post
8-4	remote		
15-1	hex wrench (5mm)		
15-2	short hex wrench(5mm)		
16-1	M10*100 SUS hex expansion bolt		
17-1	SUS hex screw(M8*14)		
17-3	SUS hex screw(M8*20)		
19-1	M8 washer		
21-1	4*14 cross drilling screw		
21-2	6*20 cross self-drilling screw		
22-1	4.2*16 cross self-drilling screw		
24-1	4.2*16 cross self-tapping screw		
24-2	cross tapping screw(4*20)		
27-1	∅8*M6*5 thumb screw		

Note: The silicone sealant and installation tools are not offered, please purchase it in local.

What you need

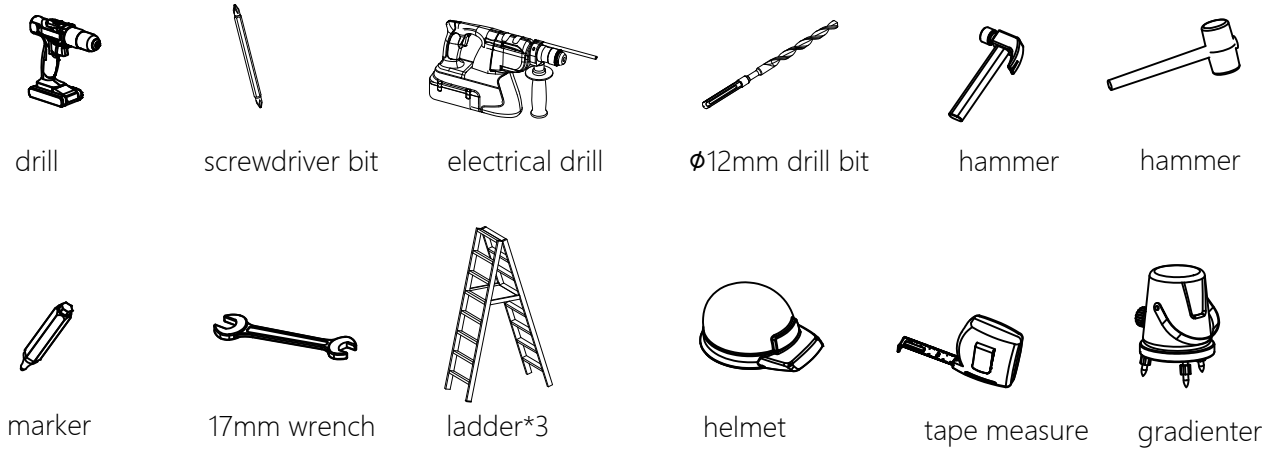

INSTALATION

Step one: Assemble the post and base plate (A1 and A2 are the pergola cable position)

1.1. Insert the base plate into the bottom of the post and fasten them

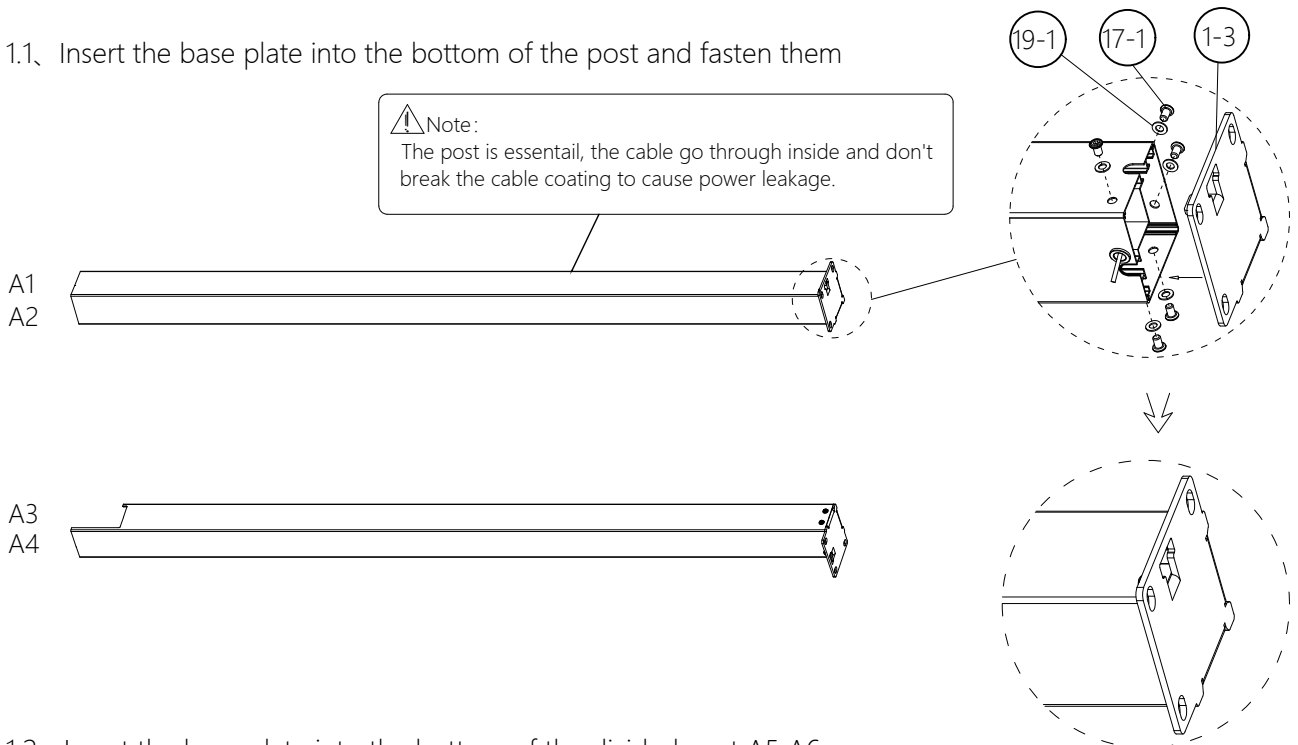

1.2. Insert the base plate into the bottom of the divided post A5 A6

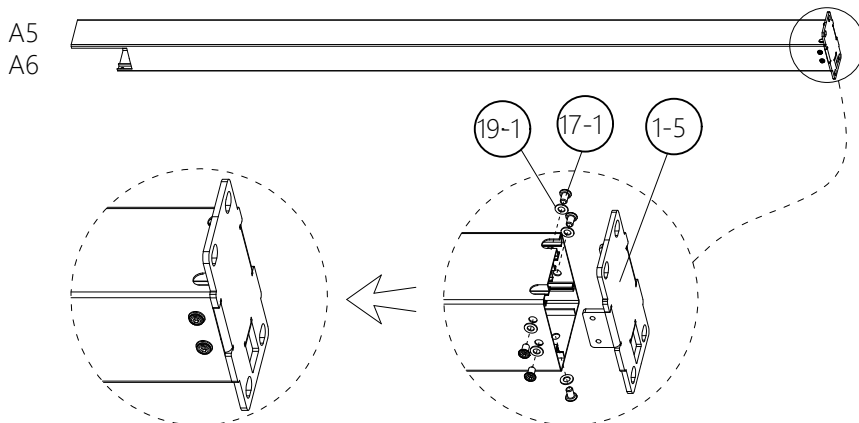

Step two: Assemble the pergola frame :do assemble beam B1with posts first

2.1、 Insert the beam&gutter B1 into the groove of post

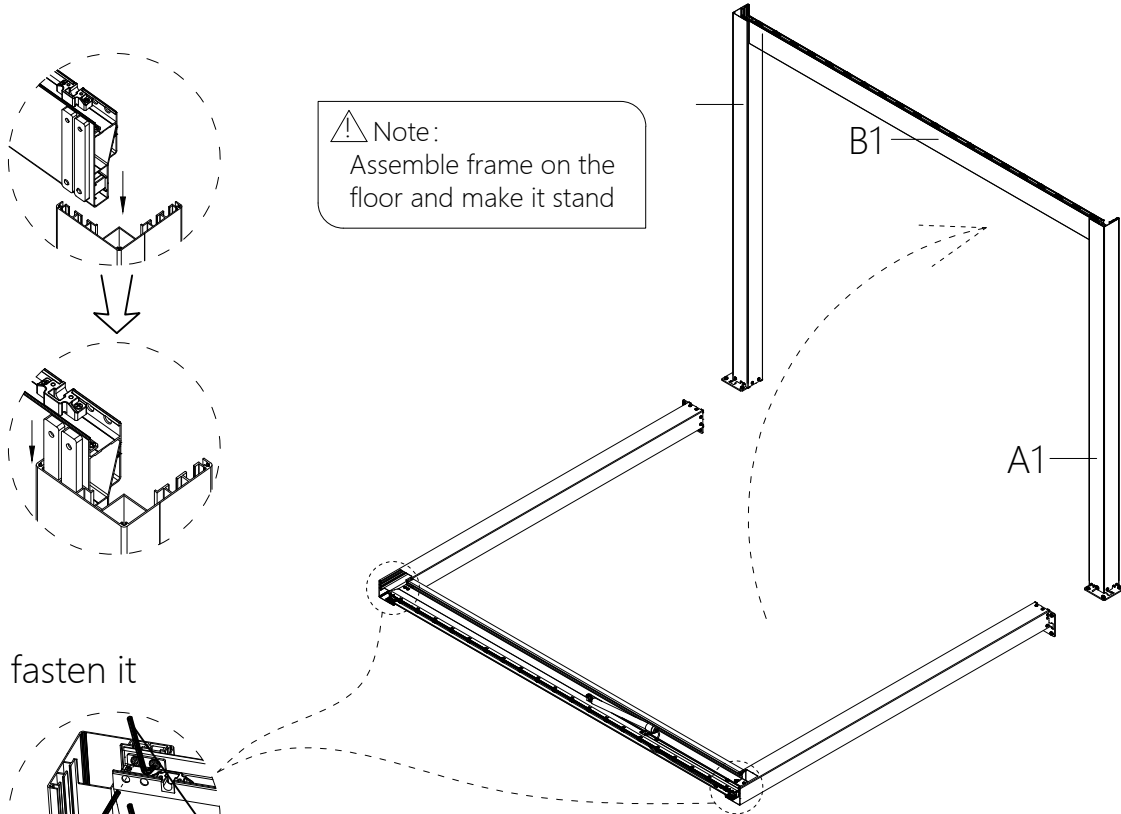

2.2、 fasten it

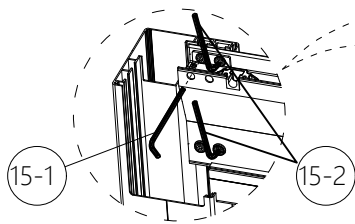

2.3、 Note: Assemble frame on the floor and set it up

Note:
1. Please ensure the pergola frame position is correct before you assemble
2. It needs at least 2 people to make the post stand up

2.4 Assemble the half pergola frame first and set it up (to stand)

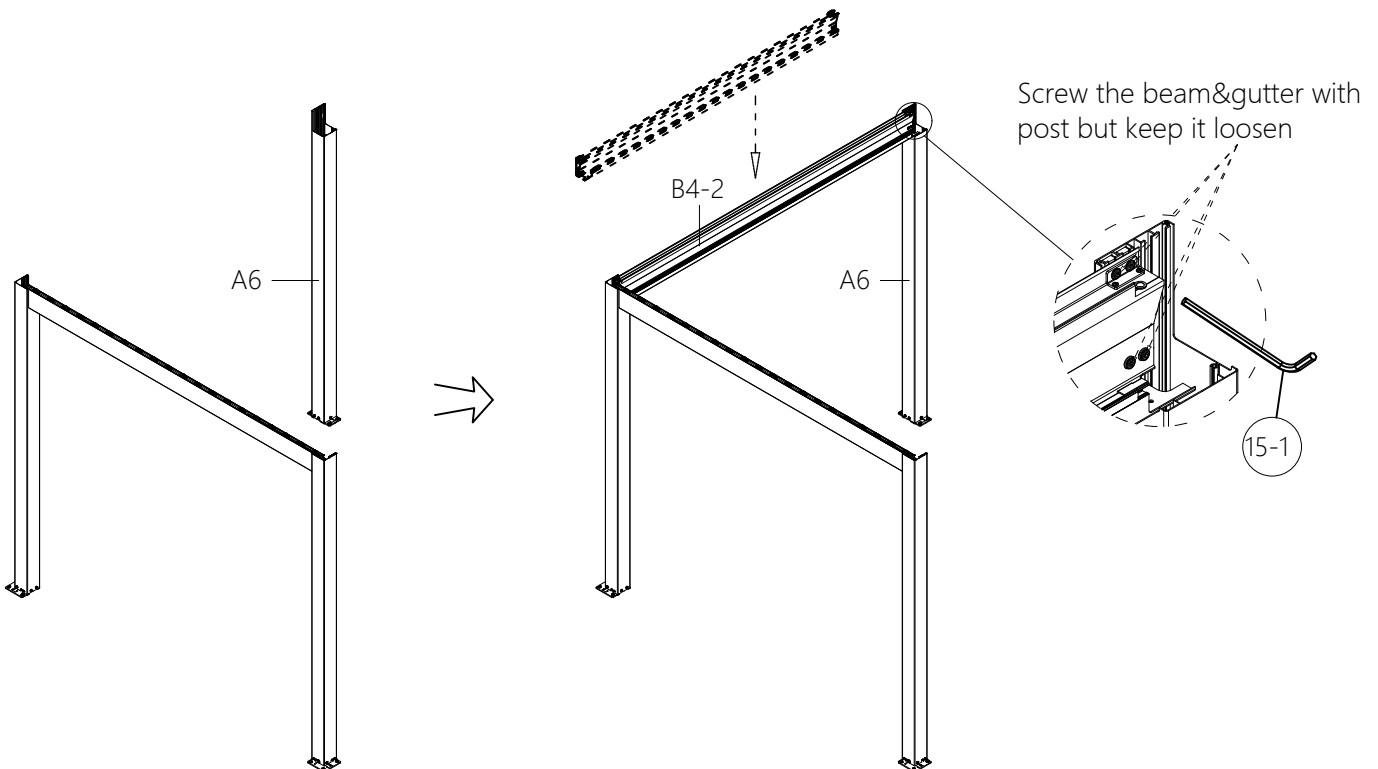

2.5、 Assemble the remaining pergola frame(assemble the U-shaped frame to stabilize the structure)

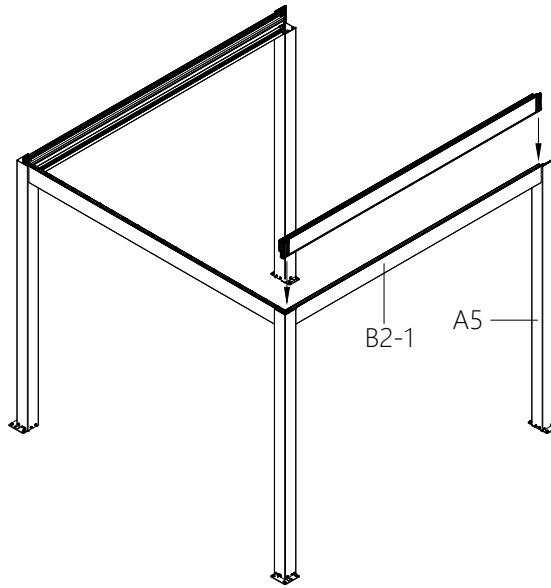

2.6、 Installing the other pergola bay to complete the whole pergola frame assembled

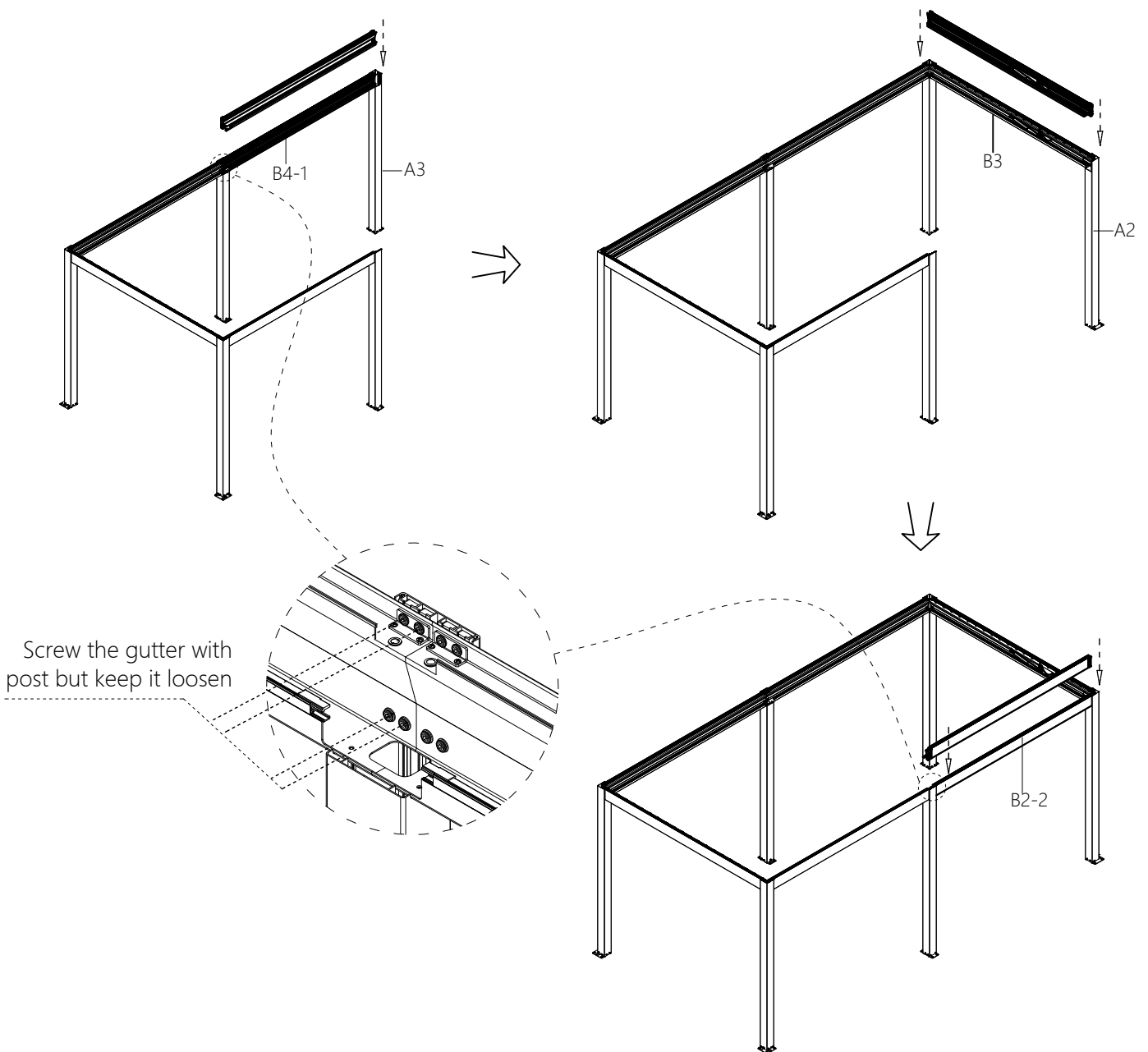

Step three: Adjust the pergola position and fix the post to the floor

3.1. Adjust the size and positioning(post spacing, parallelism, isometrics)

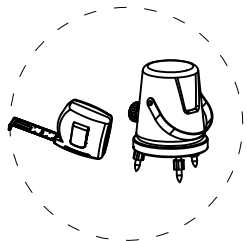

3.2. It needs 2 workers to install the middle beam&gutter connect accessory. One man pinch beams to reduce gap, the other man screw it. Don't forget to do silicone sealant when installation finished.

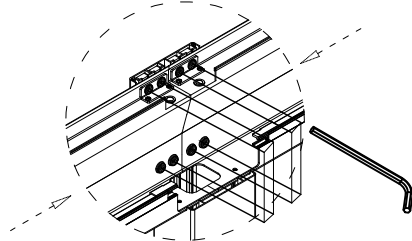

3.3. Install the L shape to strengthen accessory

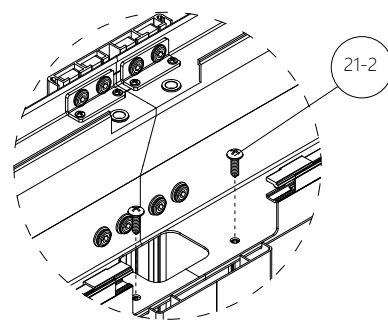

3.4. Insert the beam&gutter into the middle groove

3.4-1. Apply silicone sealant along the bottom of the U-shaped cutout in the gutter beam.

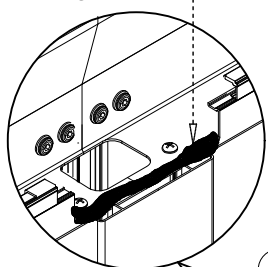

3.4-2. Note the direction of the B5 divided gutter beam: the end labeled "A" on the divided gutter beam should face the gutter beam labeled "A".

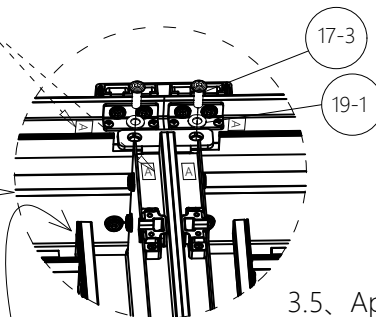

3.4-3. Secure both ends of the divided gutter beam with SUS hex screw(M8*20)

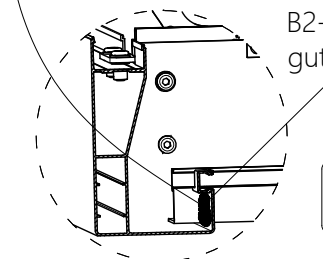

3.5. Apply silicone sealant at the intersection of the inner sides of B2-1/B2-2/B4-1/B4-2 and the B5 gutter beam

Note: Note: Wipe off superfluous silicone sealant from the gap

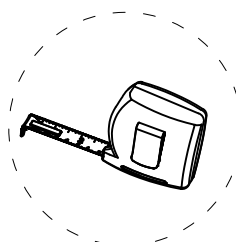
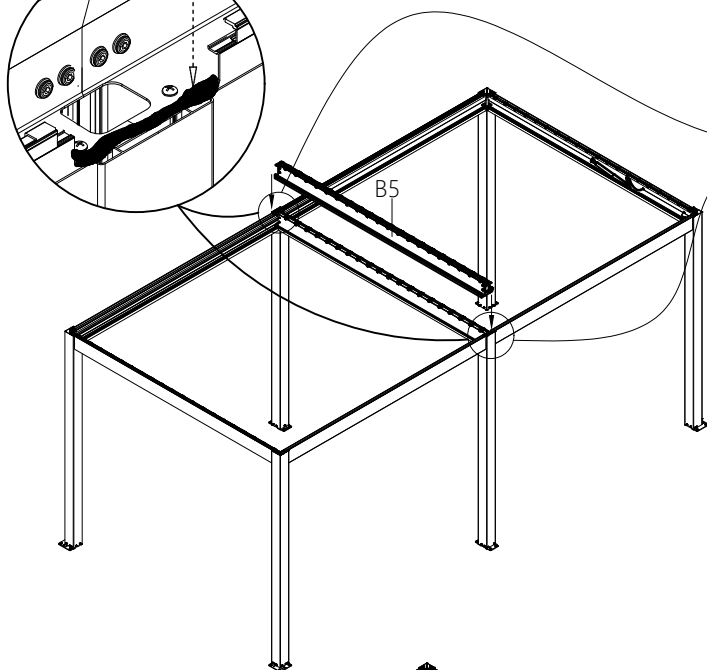

3.6. Verify check the pergola frame position beofore you fix it

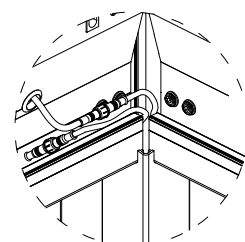

3.7. link the led light strip (ignore this sept if the pergola exclude led light)

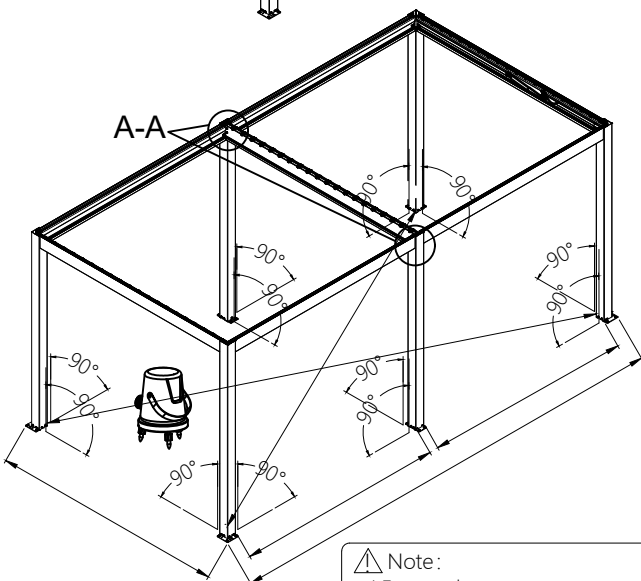

Note:
1.Ensure the post at correct position, and stand 90 degree to the floor.
2.Before you fasten the screws, you should verify the pergola's position.

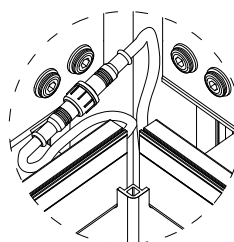

3.8. link the led light strip

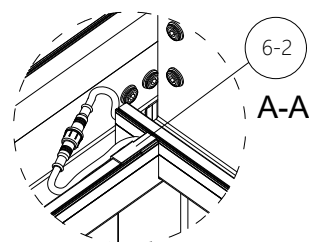

3.9. Install the gutter decoration casing

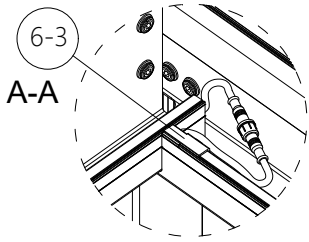

3.10、 Assemble the gutter decoration component

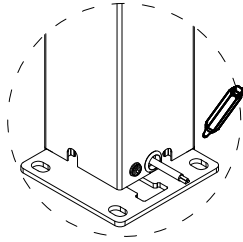

3.11、 Mark the drill holes on the concrete floor

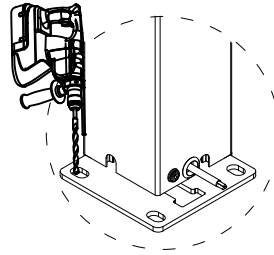

3.12、 Drill bolt holes

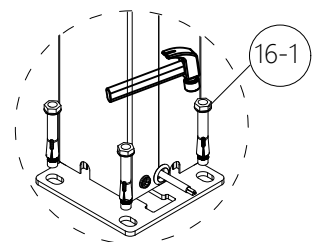

3.13、 Stuff the expansion bolts into concrete

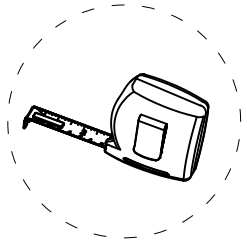

3.14、 Check the pergola position again

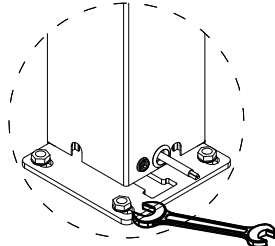

3.15、 Fasten the base plate on the floor

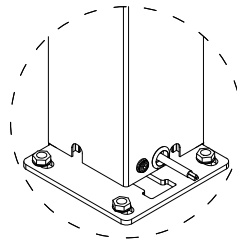

3.16、 Completed

Step four : Settle the louvers(driven louver ,common louvers)

4.1、 Take out the driven louver from the package

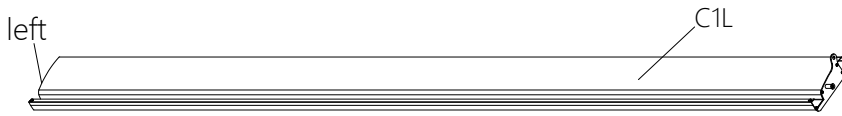
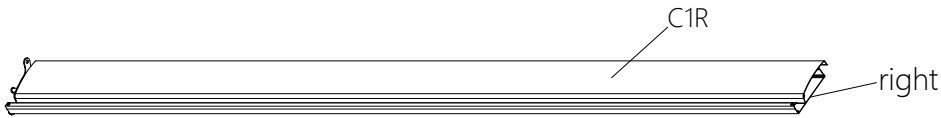

4.2、 Screw the end cap for driven louver as picture

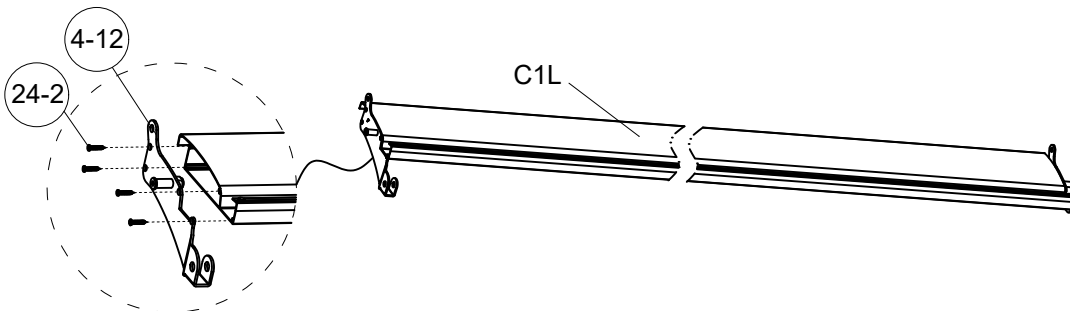
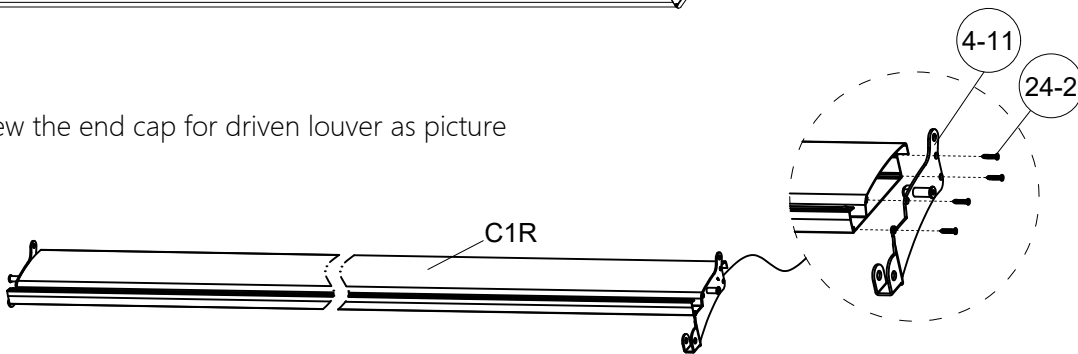

4.3. Check the drawing and mark the positions of driven louver (connecting with the motor)

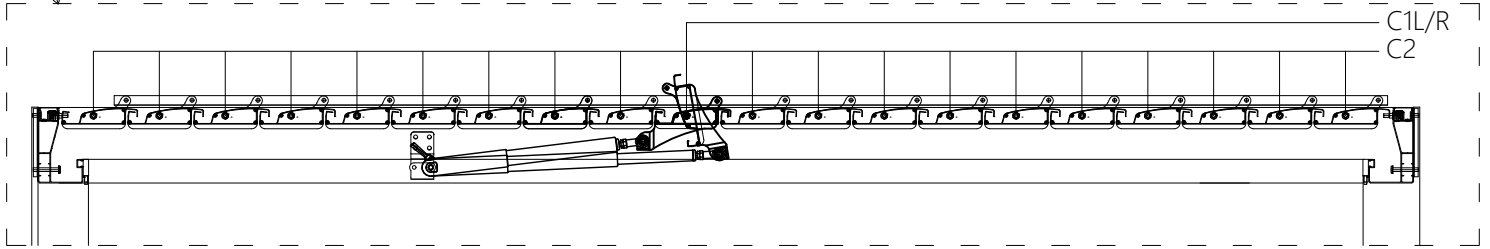
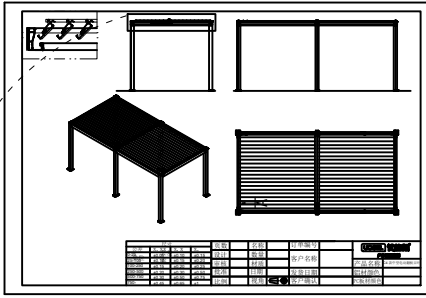

4.4. You could recognise the driven louver C1L base on the installation guide

4.5. Put the remaining louver is same orientation as the driven louver C1L you could put the louvers from any side

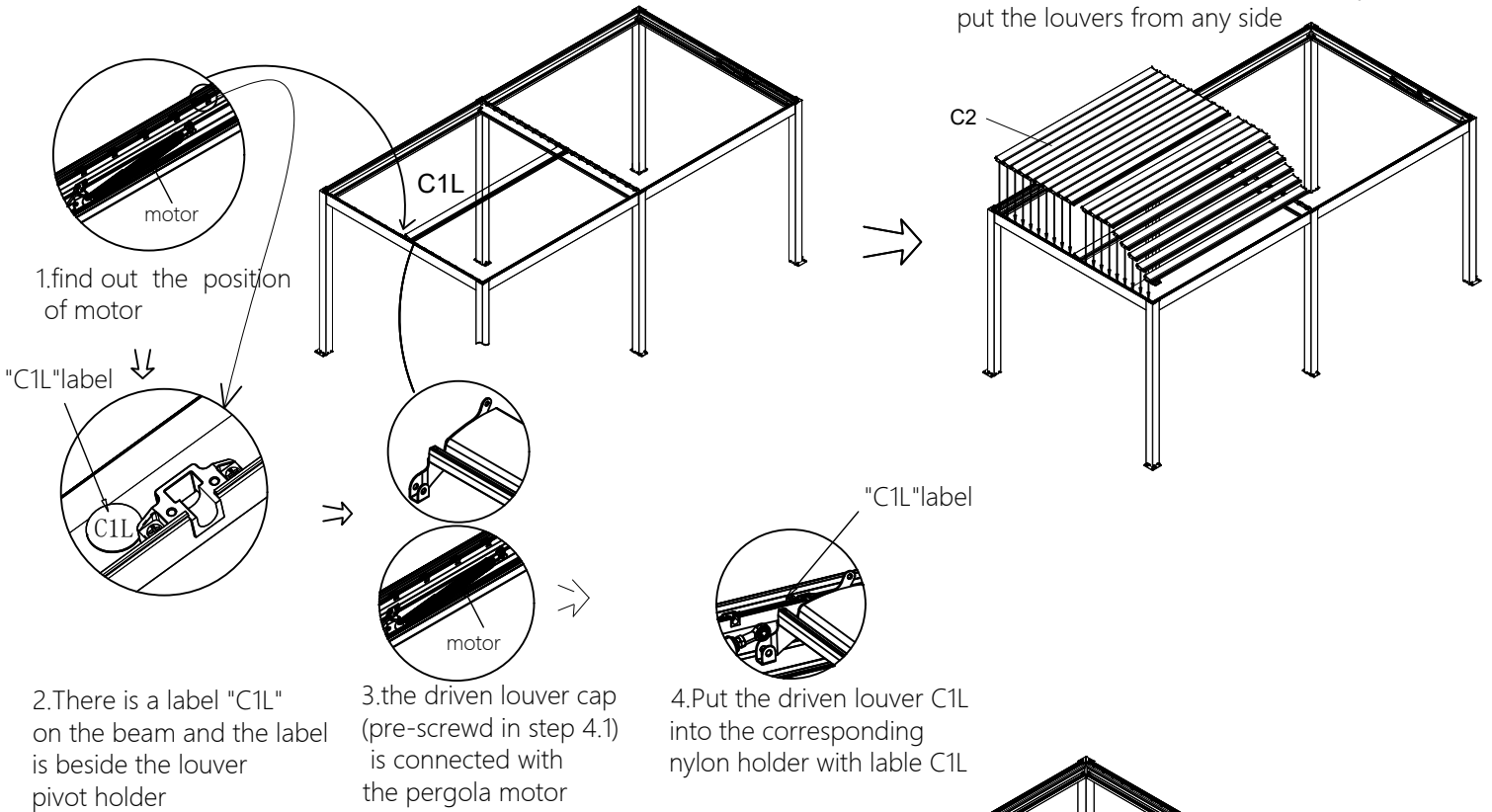

4.6. When all louvers are installed, then fasten the caps

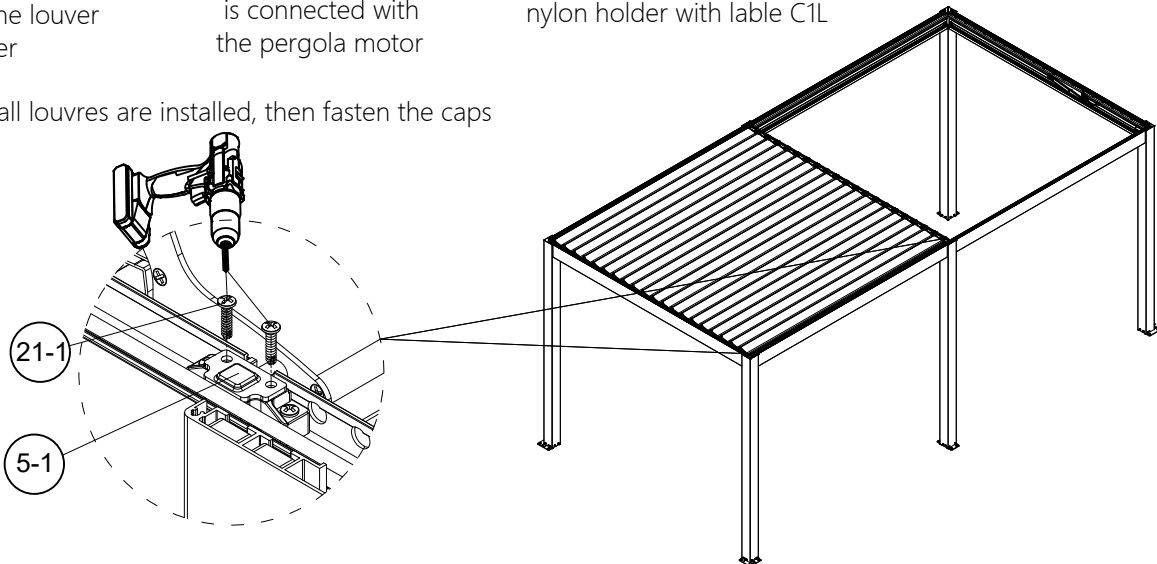

4.7. Install the connection bar before settle the remaining louvers of the other half bay

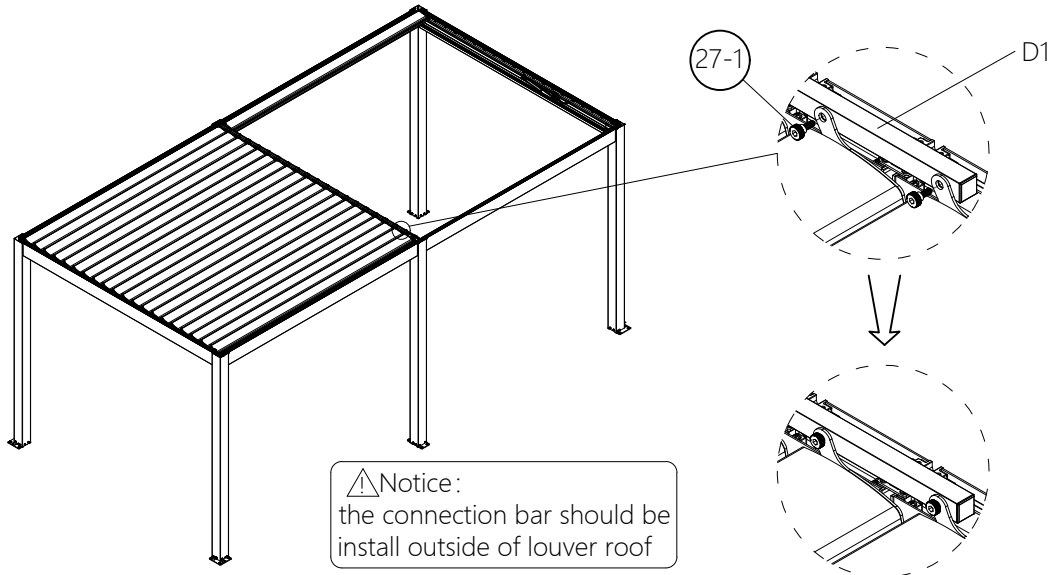

4.8. Fasten the louver pivot caps since each louver is finished

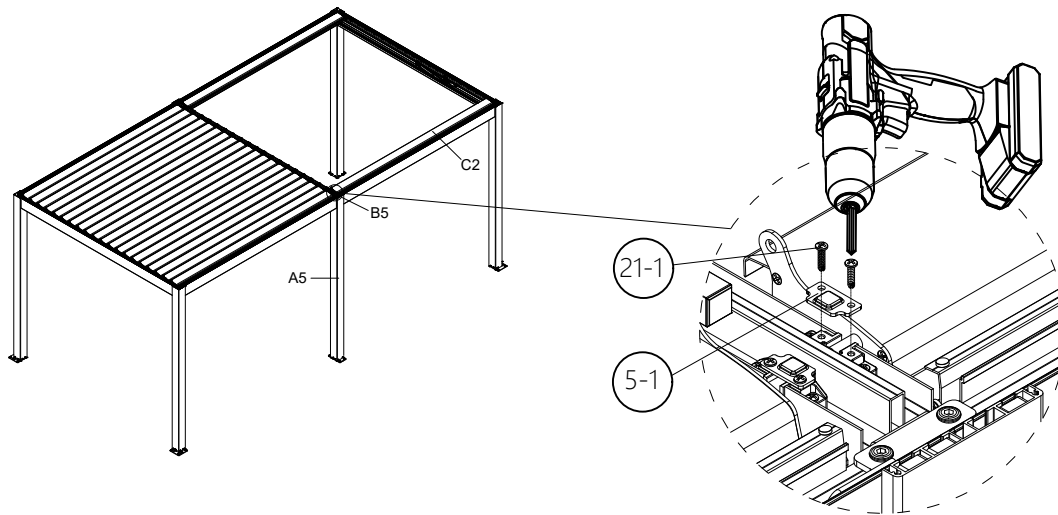

4.9. Install remaining louvers and caps

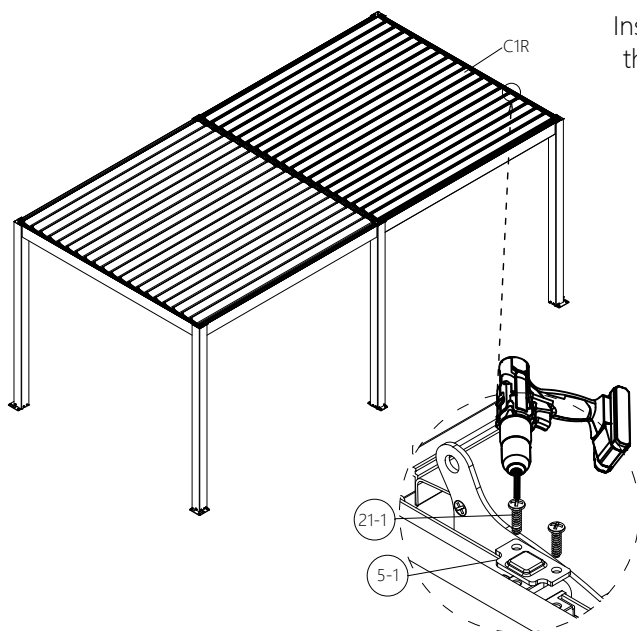

4.10. Assemble the driven louver

Install the connection bar through the gap of louvers

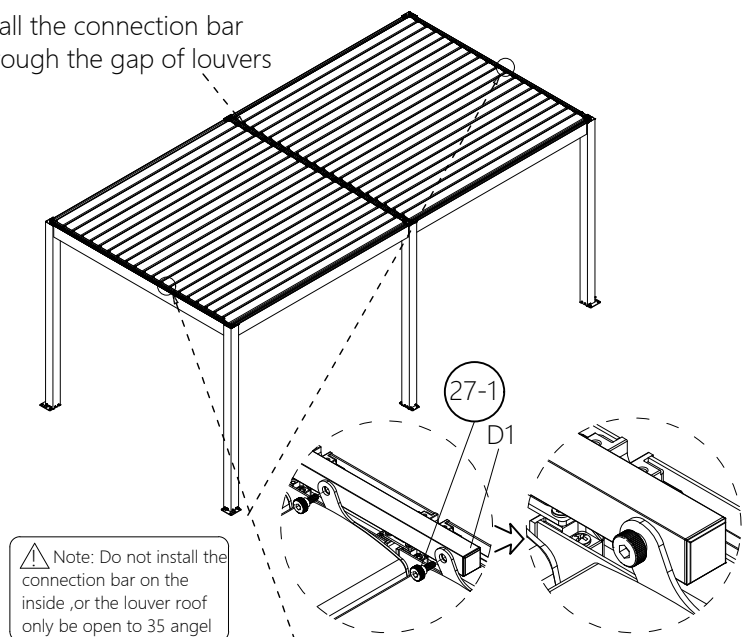

4.11、 Connect the driven louver with motor

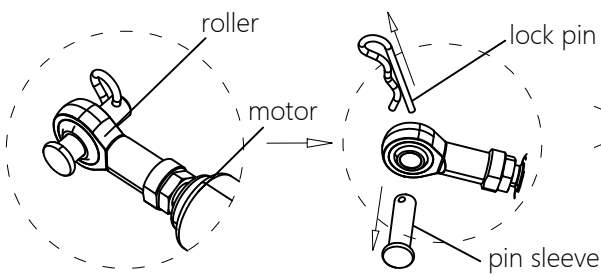
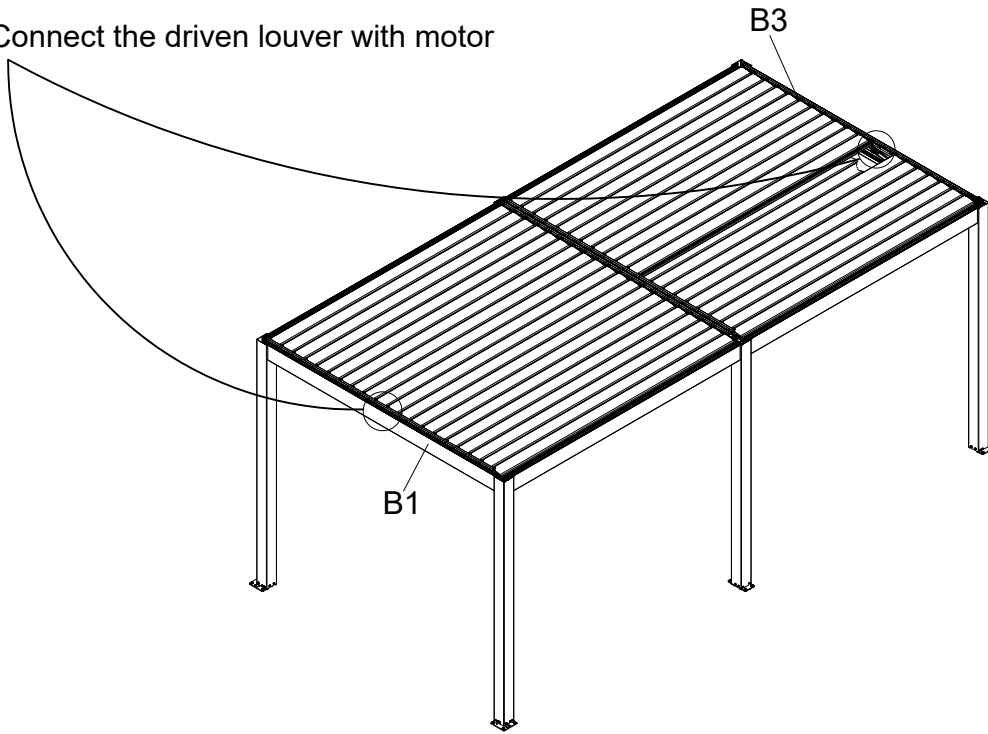

4.11-1、 take apart the pre-assembled lock pin and sleeve in advance

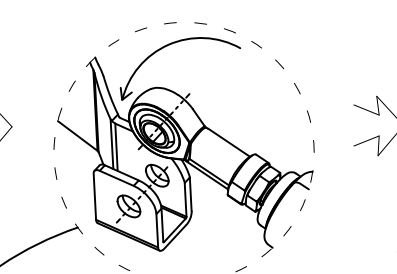

4.11-2、 align the motor roller hole with driven louver blade

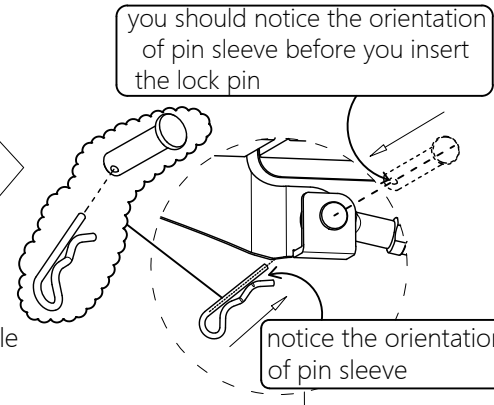

you should notice the orientation of pin sleeve before you insert the lock pin

notice the orientation of pin sleeve

There are two situations that are difficult when you install it.

Situation 1: The motor roller hole is not aligned with the louver blade, and the roller is positioned ahead

screw the nuts to adjust the roller position

Adjust the motor roller to align with the louver blade.

nut

△note: the tolerance of the roller head stretching is $\pm 2.5\text{mm}$

Situation 2: The motor roller hole is not aligned with the louver blade, and the roller is positioned short

screw the nuts to adjust the roller position

adjust the motor roller to align with the louver blade

4.11-3、 insert the pin sleeve first and then insert the pin into the sleeve

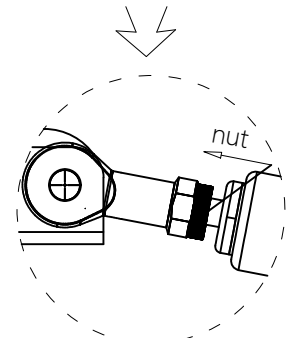

4.11-4、 screw the nuts to fasten the motor with driven louver blade

Step five: Connect to the local power supply

5.1、 Before insert the transformer into the post , you should connect to the local power supply of voltage

5.2、 Insert the transformer into the post.

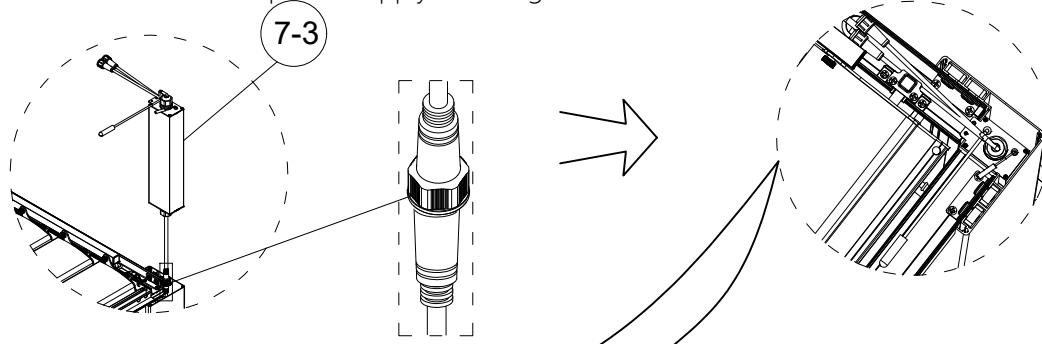

5.3、 Link the corresponding connectors to the transformer

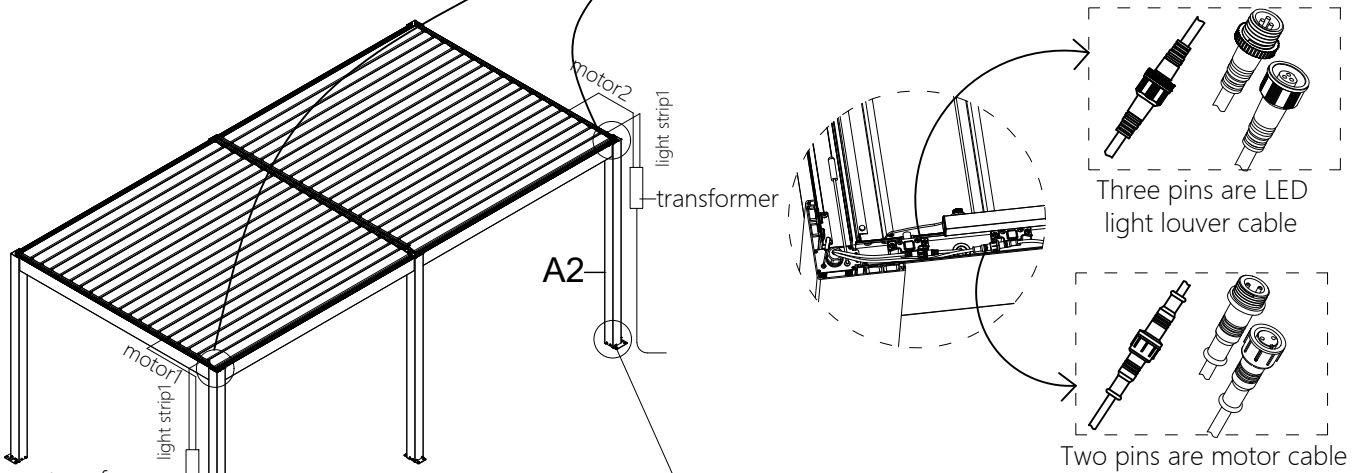

5.4、 How to link to local power supply

⚠ Note:
1、 Ensure wiring follows the labels.
2、 Properly connect to the ground wire.
3、 Voltage leakage protection swith is needed to connect to pergola

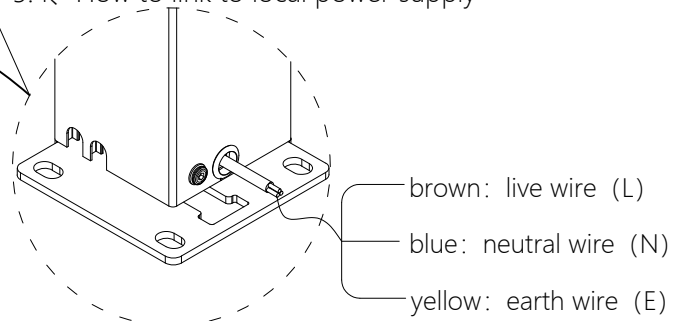

Step six: Remote control pair button

(Generally the factory has paired button, if there is no pair button according to this step operation)

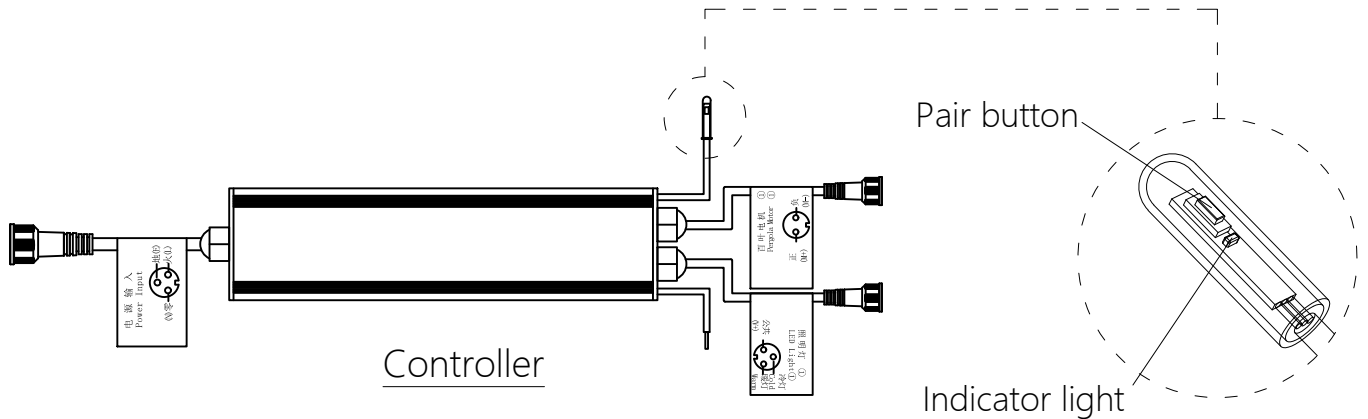

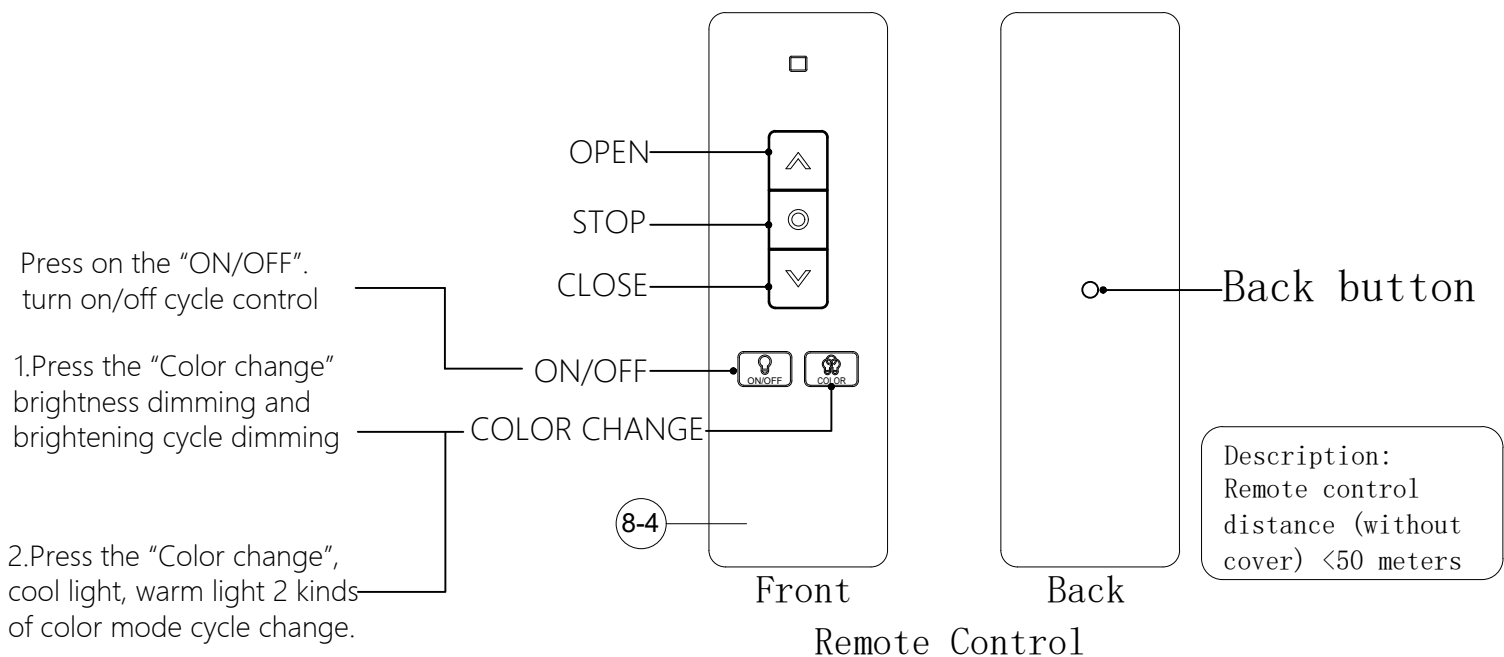

6.1 Pairing (Quick pair button when the controller is not sealed inside the finished product)

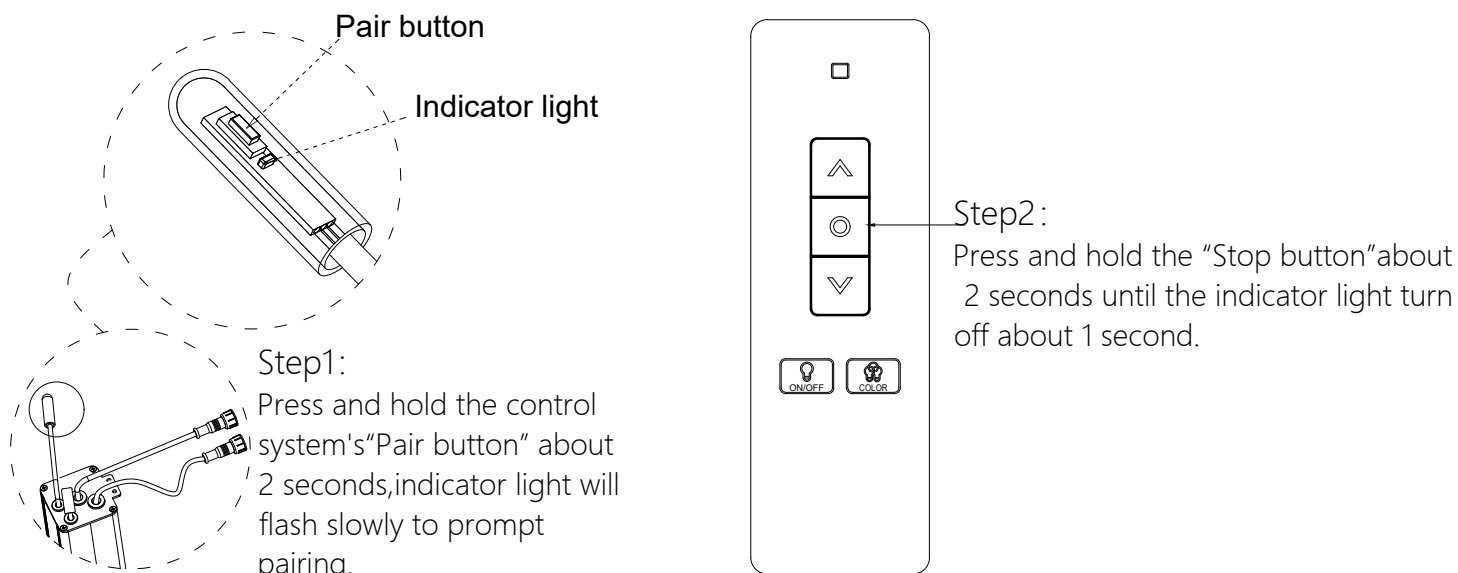

6.2、 Switching direction

Note: After installing on the finished product, if the running direction is not corresponding to the remote control, please switch the direction.

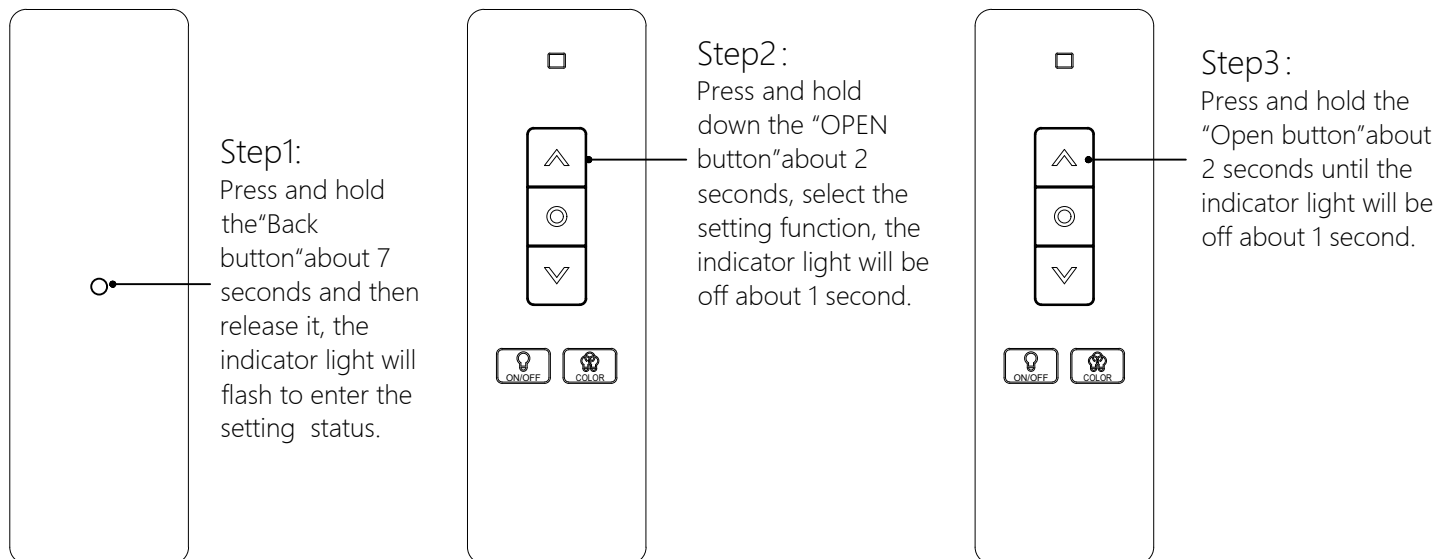

6.3 Delete the Remote Connected with Control System

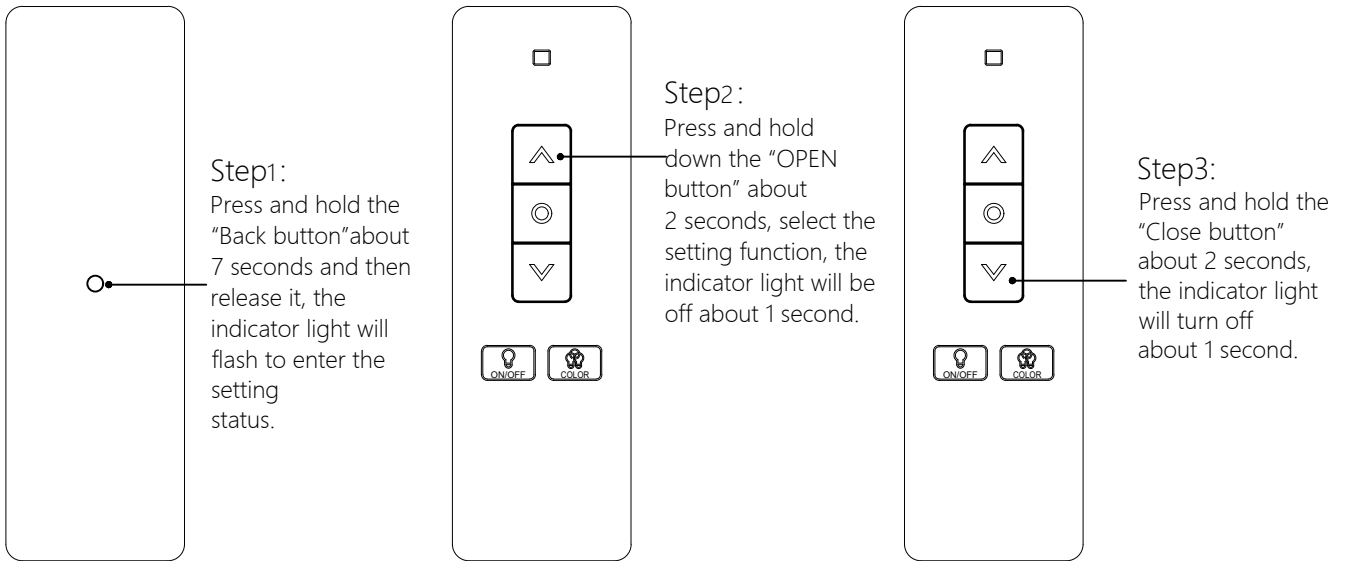

6.4. Reset

Note: All logics in the system are cleared ,restore factory resetting

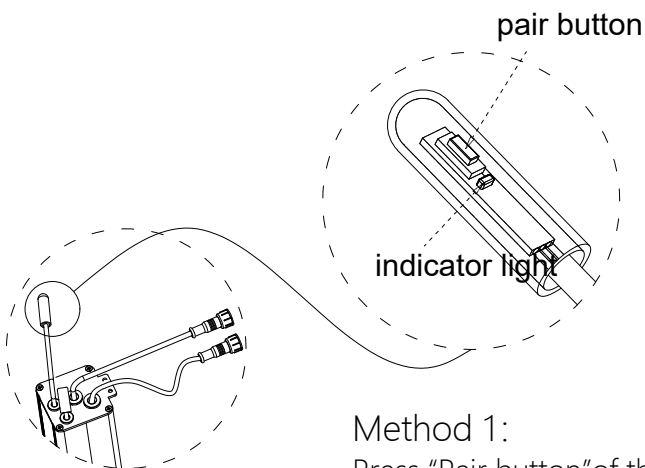

Method 1:

Press "Pair button" of the control system 4 times in a row quickly, and press and hold about 3 seconds for the fifth time, and the indicator light will be off about 3 seconds.

Method 2:

-1) Press and hold "Back button" about 7 seconds, (for first 2 seconds, the indicator light flashes slowly to enter pairing status, and up to 7 seconds, the indicator light flashes quickly to enter the setting status).

-2) Press and hold "Stop button" about 2 seconds to select the setting function, the indicator light will be off about 1 second.

-3) Press and hold "Close button" about 2 seconds, and the indicator light will be off about 3 seconds.

Step seven: install the beam & gutter flashing, post top cover and base plate cover

7.1. Check thoroughly, then open the right louver and install the connection bar

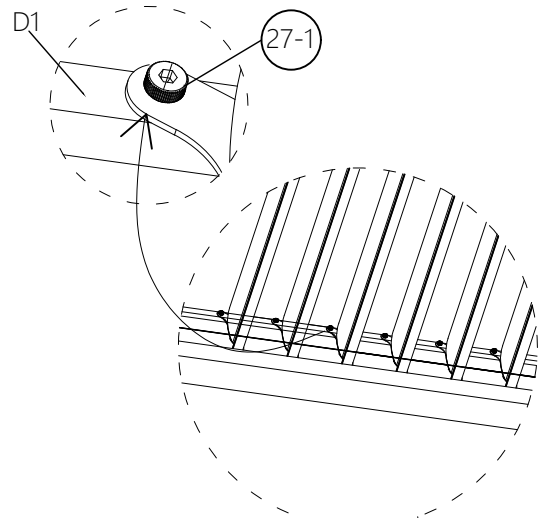

Install the connection bar through the gap of louvers

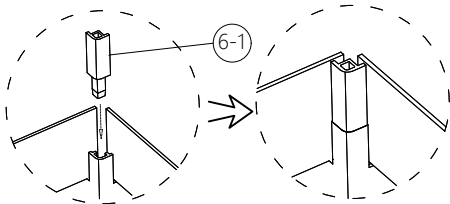

7.2 install the gutter corner insert bar

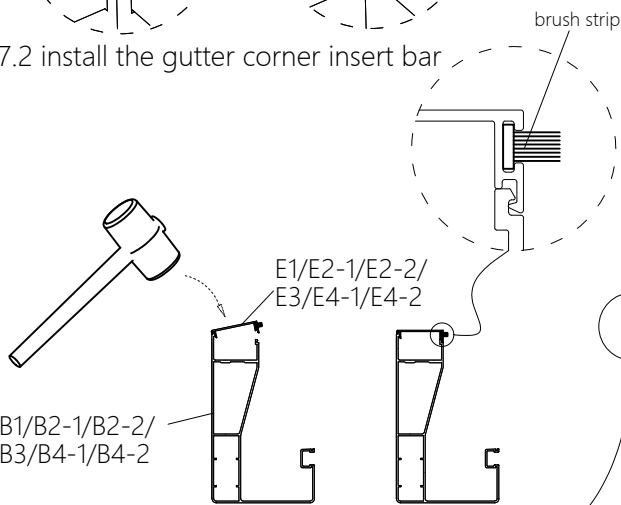

7.3 Use rubber hammer to tap the beam flashing into groove, note wide hook is at inner side.

(It is easy to tap the flashing when the louvers are opened.)

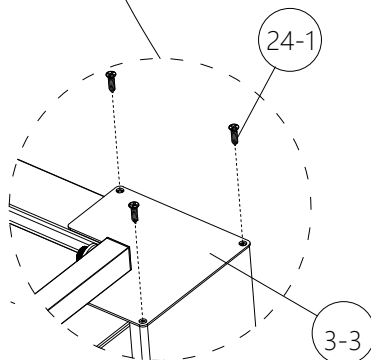

7.4 Install the post top cover at four corners.

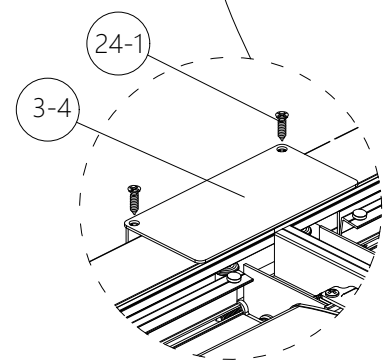

7.5 Install the middle post top cover

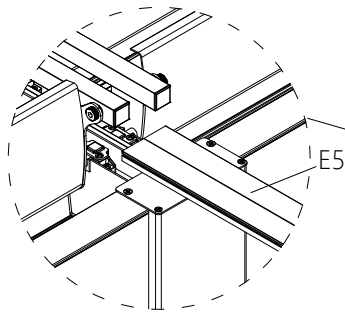

7.6 Insert the middle beam flashing

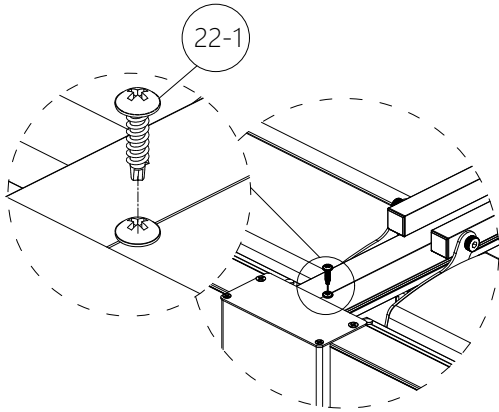
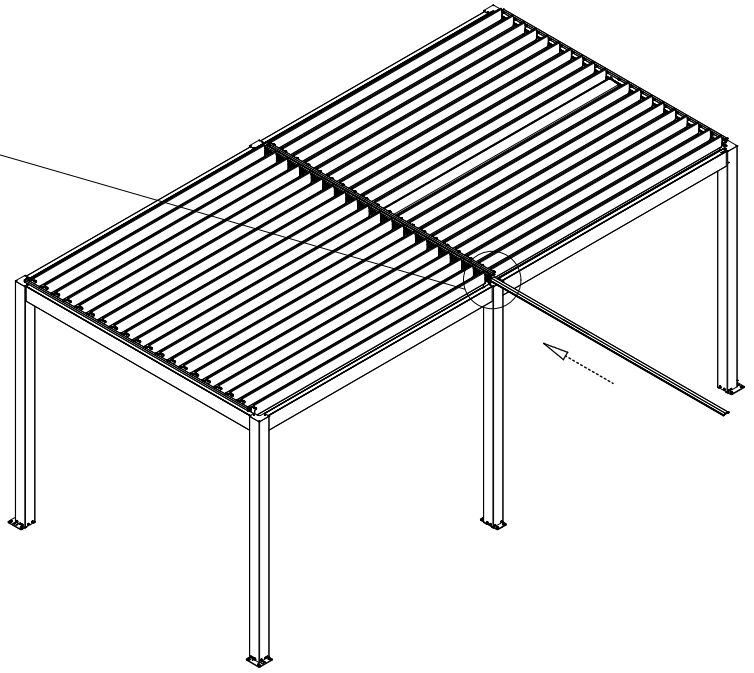

7.7 Screw the beam&gutter flashing.

7.8 install the base plate covers

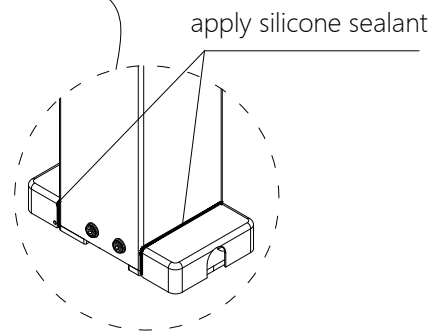
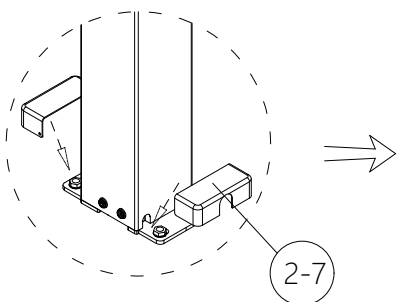
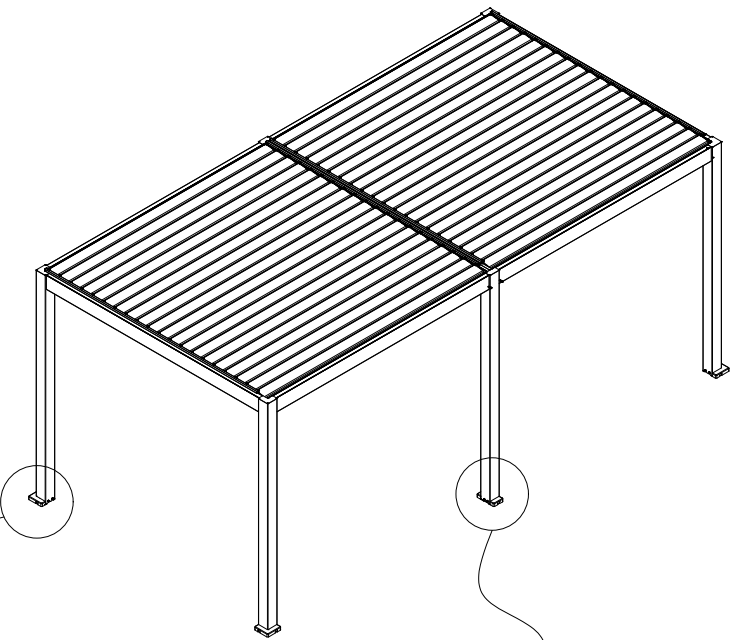
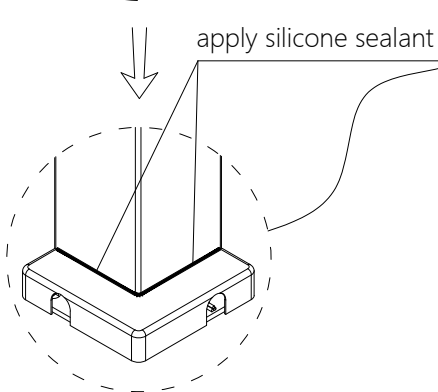
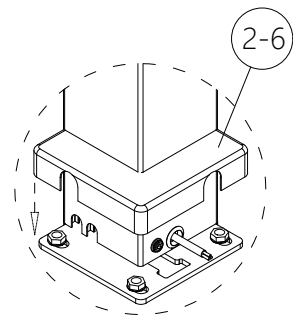

Note: Silicone sealant is not offered ,you should purchase it locally

Completed

Step eight: Check the product functions

- 8.1、 Ensure the pergola has been connected to the leakage protection switch.
- 8.2、 Verify the power supply of the pergola
- 8.3、 Verify the function of the remote
- 8.4、 Check whether the motor is running normally
- 8.5、 Verify the LED light function
- 8.6、 Check other equipments

HOW TO PAIR TUYA APP

Step One :Clik open TUYA app

1. Prepare a public wifi for the pergola
2. Open the phone bluetooth and TUYA app

Tip:
it needs 2.4GHz wifi



When you open the Tuya app, the 'Add Pergola' button will automatically appear on your mobile screen

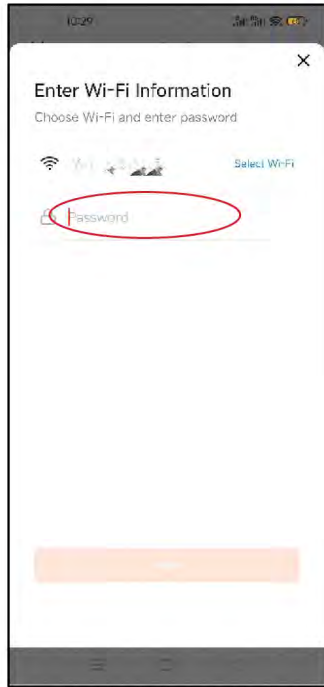

Enter the WLAN password



Click 'Done' when you have successfully added it.

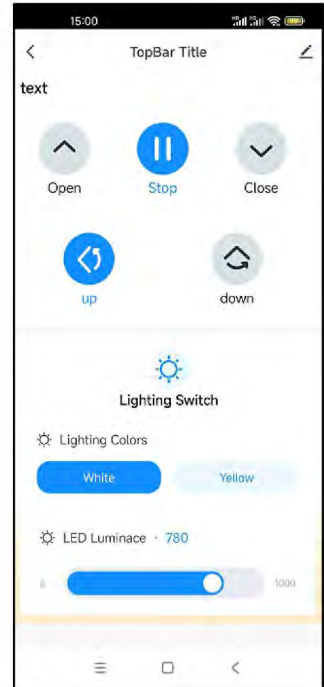

Operation screen

3. How to delete the APP control



TUYA APP control screen

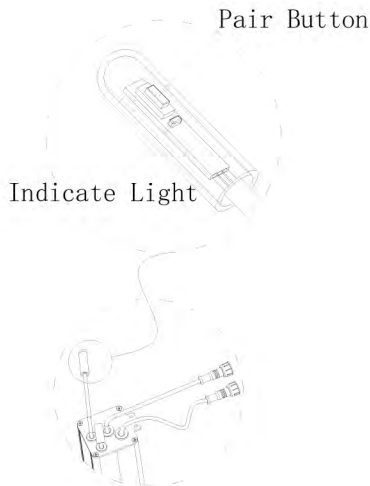

Press and hold the pair button about seven seconds until the indicate light turn off one second

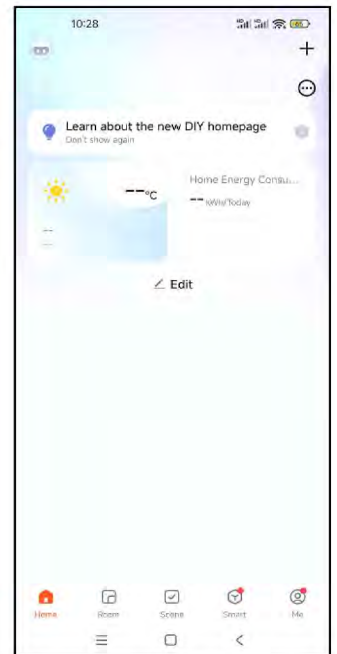

Refresh the app control screen, and you will find that the pergola has been deleted

How to authorize account to your family members

TUYA APP

When you connect to tuya app successfully ,you can share the account to your family members

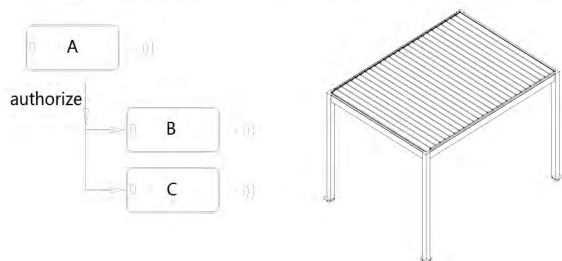

Tips:

- 1.The owner's phone (A) connect to pergola , he can operate the pergola by his phone A.
- 2.The the other family members also download TUYA app and sing in.The account for logging into the app should be linked to a mobile phone number or accessed using a mobile phone number.

1.Create a family group in the phone (A)

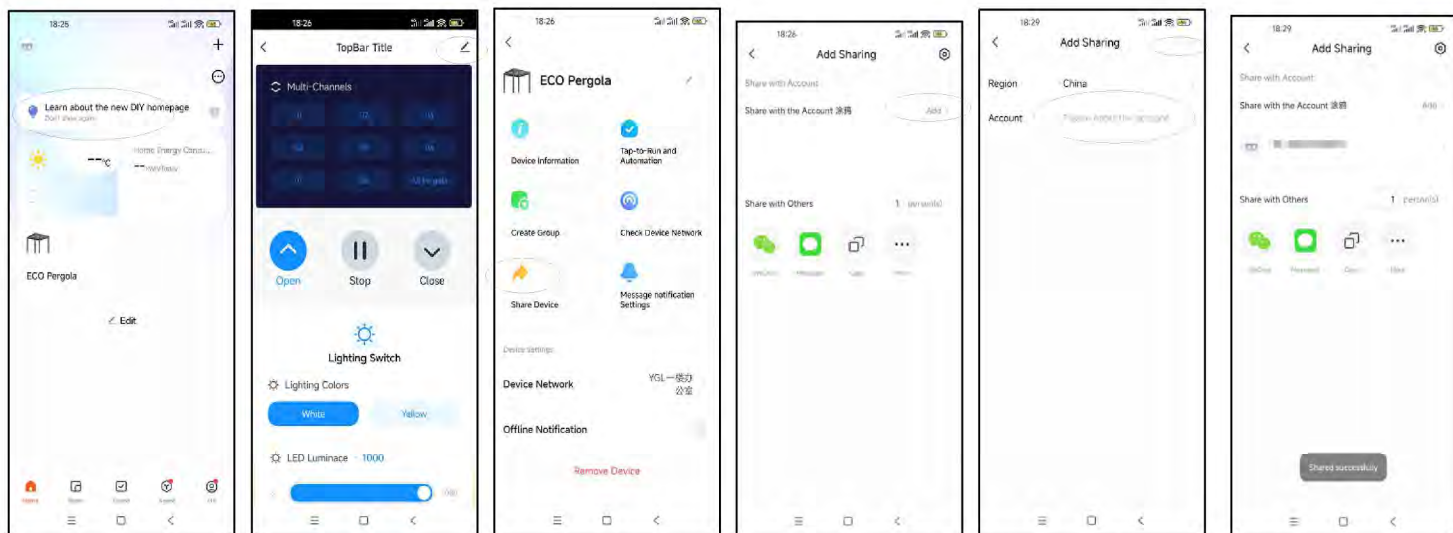

- 1.1、click"pergola"
- 1.2 click "setting"
- 1.3、click"sharing the device "
- 1.4、click "add"
- 1.5、input the account you want to share
- 1.6、 success

2. The other family members accept the invite on their Phones

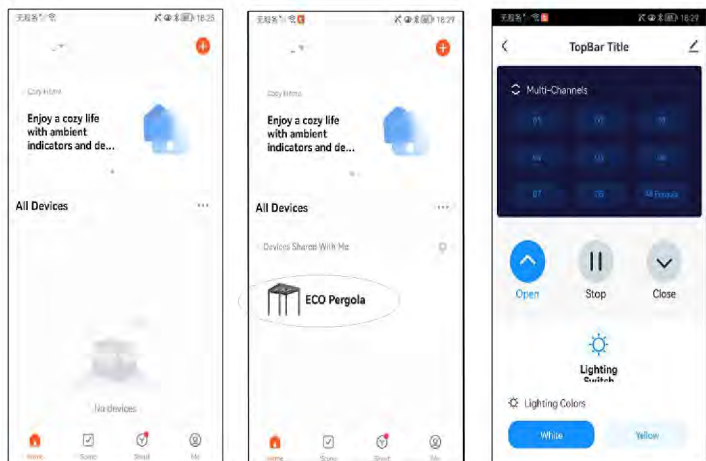

- 2.1、shortscreen of invitee
- 2.2、click the invited pergola
- 2.3、 completed shortscreen

WALL MOUNTED INSTALLATION INSTRUCTION

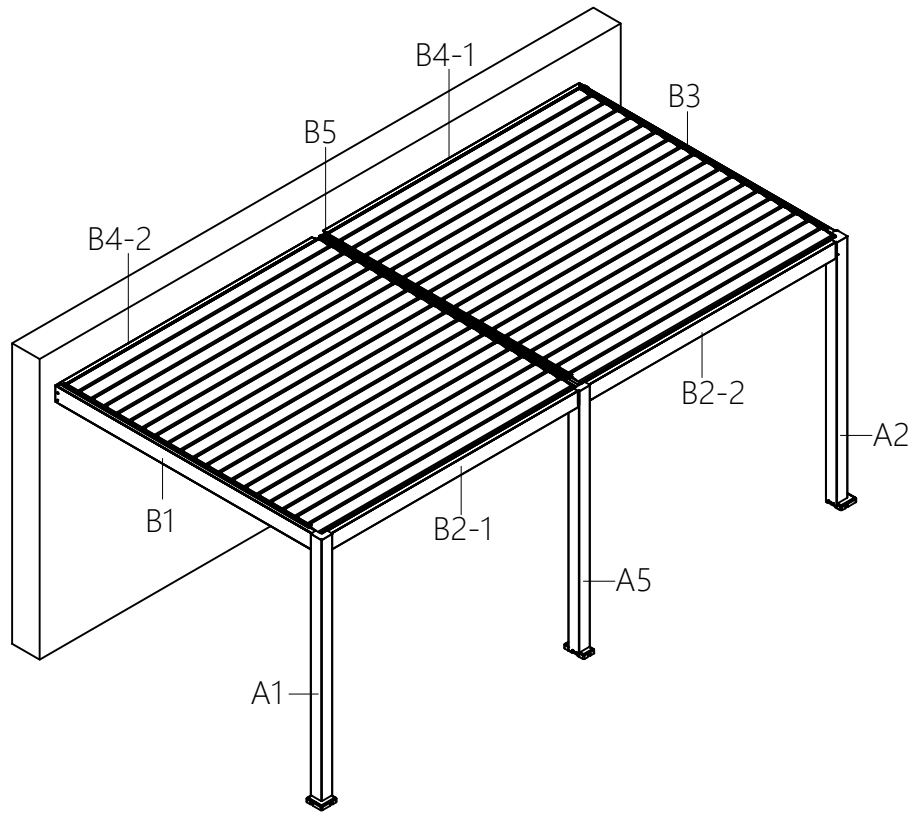

What you need

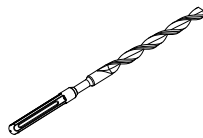

∅12mm drill bit

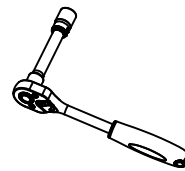

17mm wrench

Hardware

code	Name	photo	remarks
17-1	SUS hex bolt (M8*14)		
19-1	M8 washer		
19-2	M10 washer		
31-1	Wood screw (M10*100)		
31-2	expansion hose (M14*75)		
32-1	diameter 30 lid		

Step 1、 Fix the wall mounted beam B4-2 B4-1 on the wall

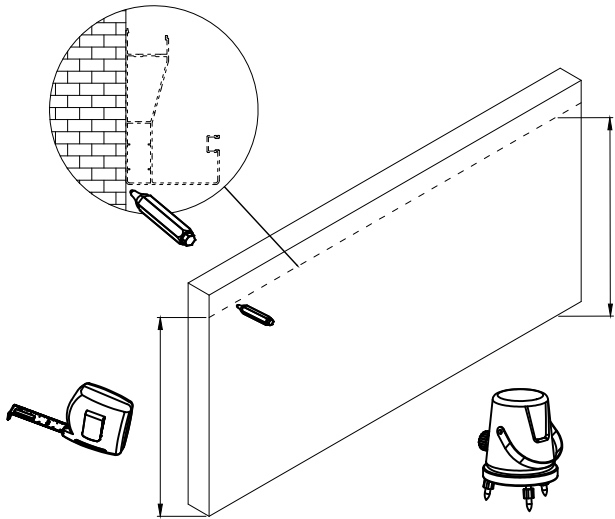

1.1、 Take use of gradienter to mark the wall mounted beam height and position

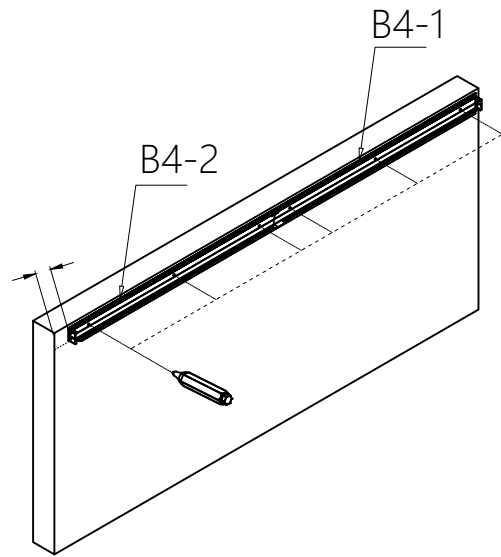

1.2、 Mark the position of the holes by aligning with the holes on the gutter. You should drill the holes in local to ensure it accurate for your house.

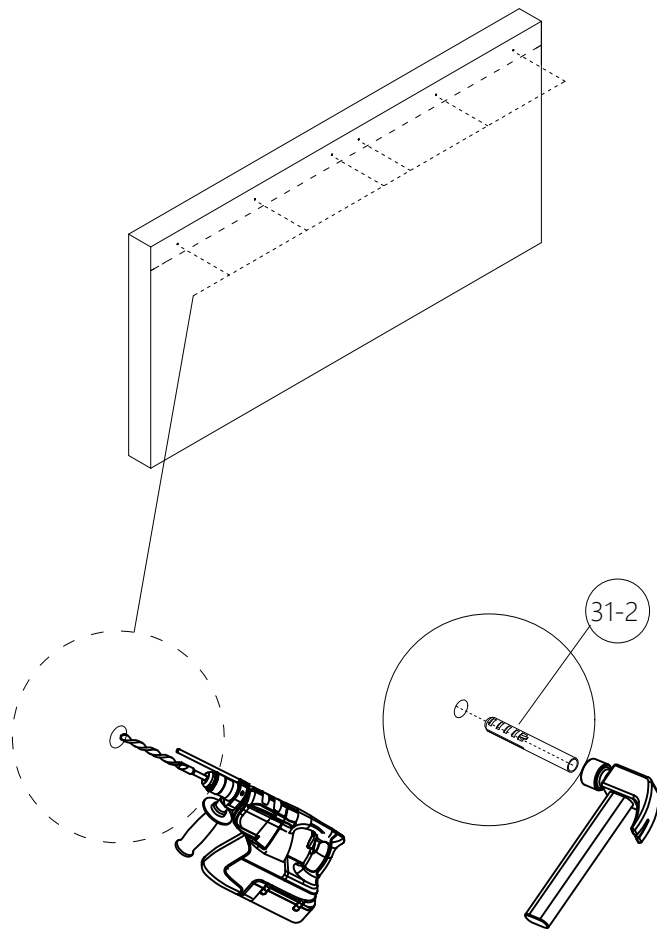

1.3、 drill holes on the sign pot

1.4、 Stuff the expansion hose into the holes

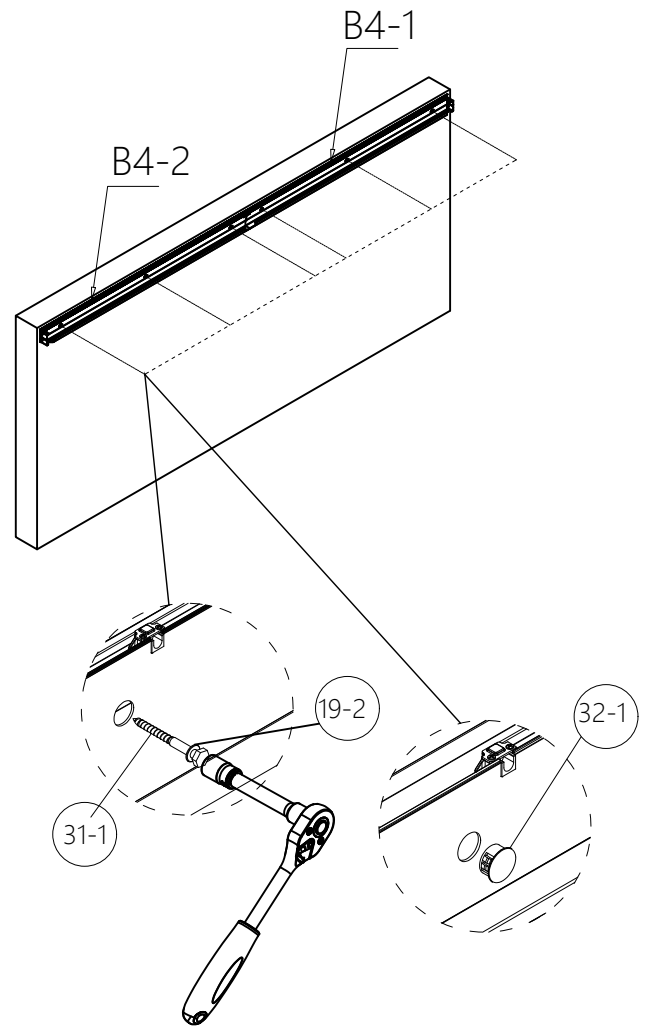

1.5、 use wrench to screw the beam B4-1 B4-2 on the wall

1.6、 stuff the lid

⚠ Notice:
Double check the position
before fasten the wood screw

Step 2: Assemble the pergola frame

2.1. Insert the beam into the post groove

2.1-2. Take apart these two screws first

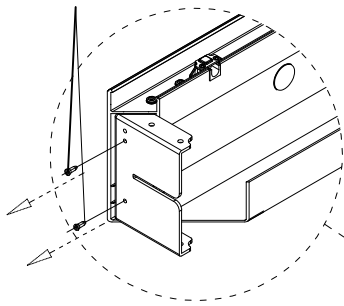

2.1-1. Combine the post with beam & gutter

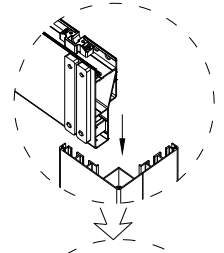

2.1-3. Combine the beam & gutter with junction

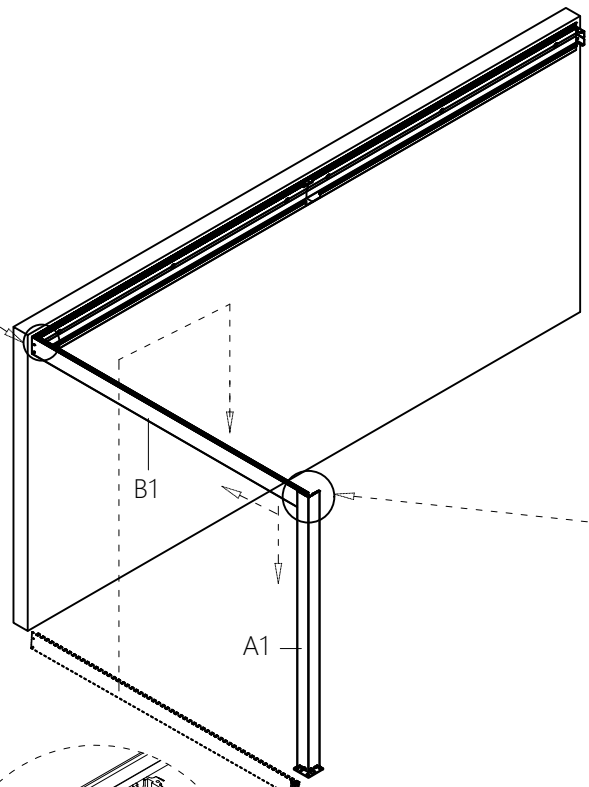
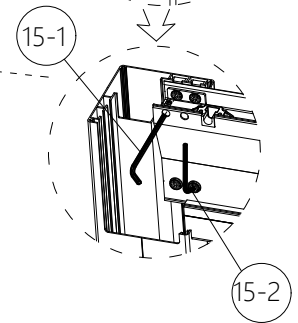
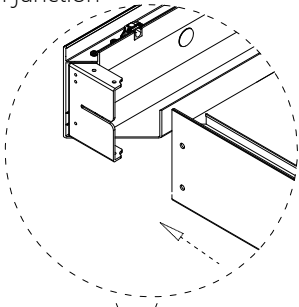

2.1-4. Fasten the screw back

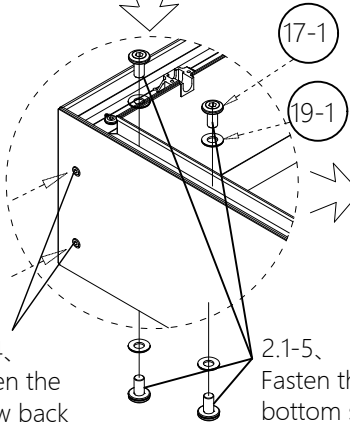

2.1-5. Fasten the up and bottom screws

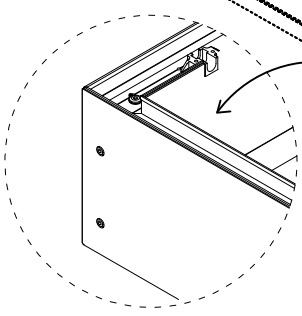

The inside connection of the beam and gutter need to place silicone

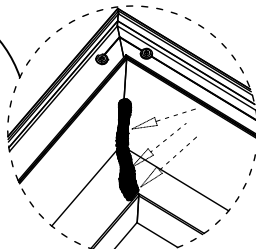

2.2. Refer to the previous installation steps to assemble the remaining frame parts

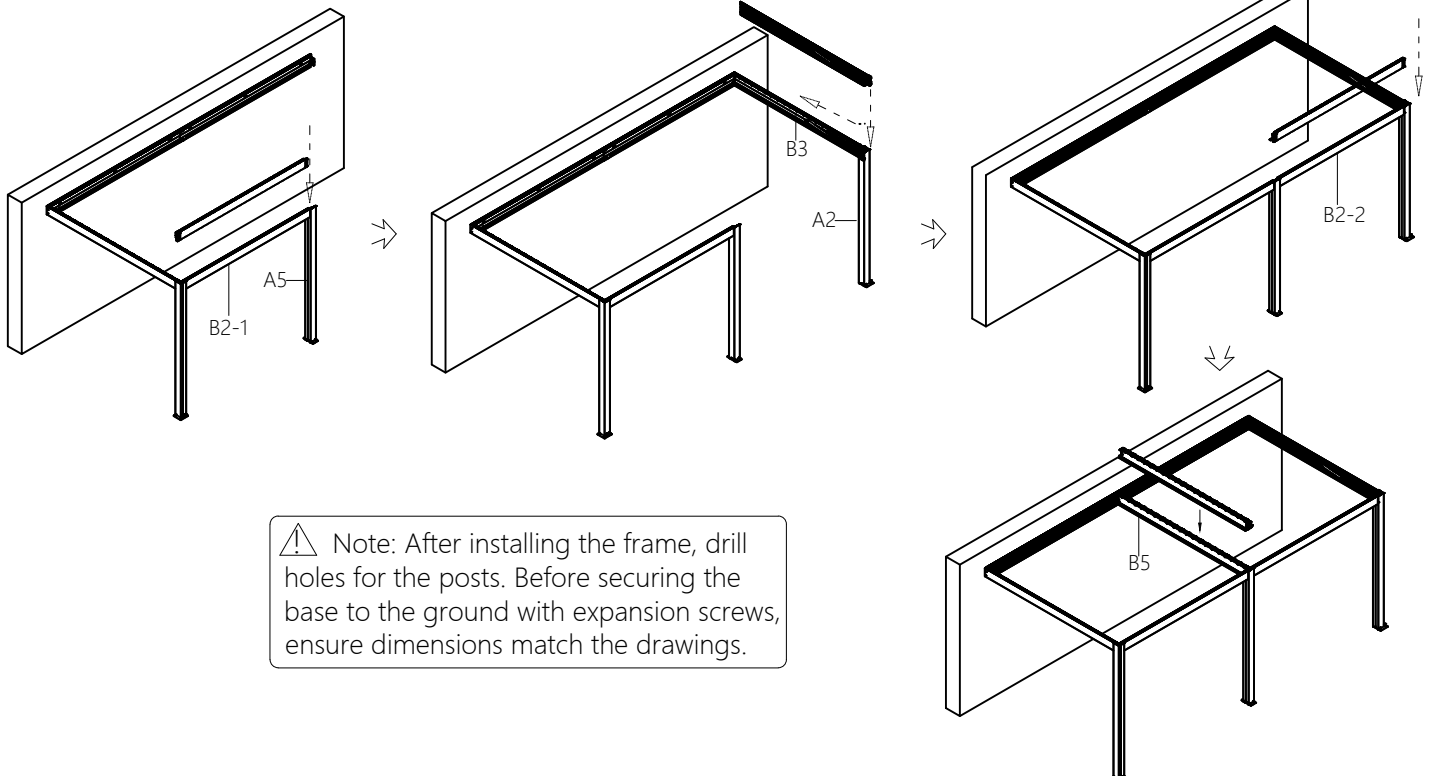

⚠ Note: After installing the frame, drill holes for the posts. Before securing the base to the ground with expansion screws, ensure dimensions match the drawings.

Refer to steps 3, 4, 5, 6, and 7 to go ahead the next installation phase

There are two special space should be focus on :

-1.First, install the drive louver and ambient light wiring, and arrange the wires properly.

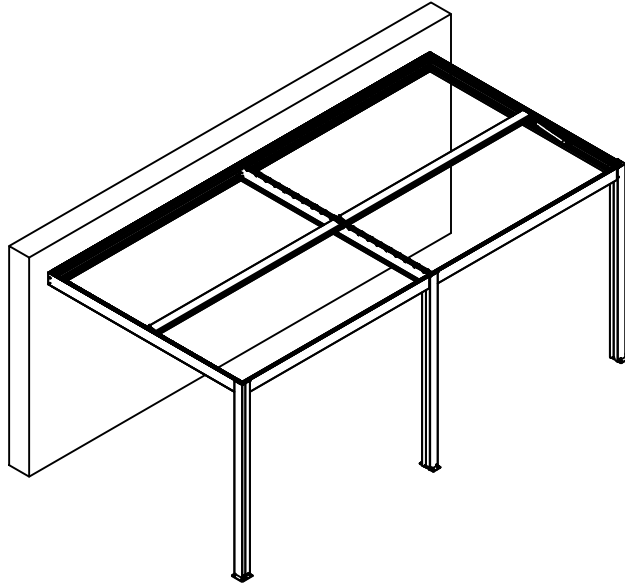

-2..Install the beam flashing E4-1 E4-2 of wall mounted beam when install all the louvres(Note: due to the wall position and difficult to install the beam)

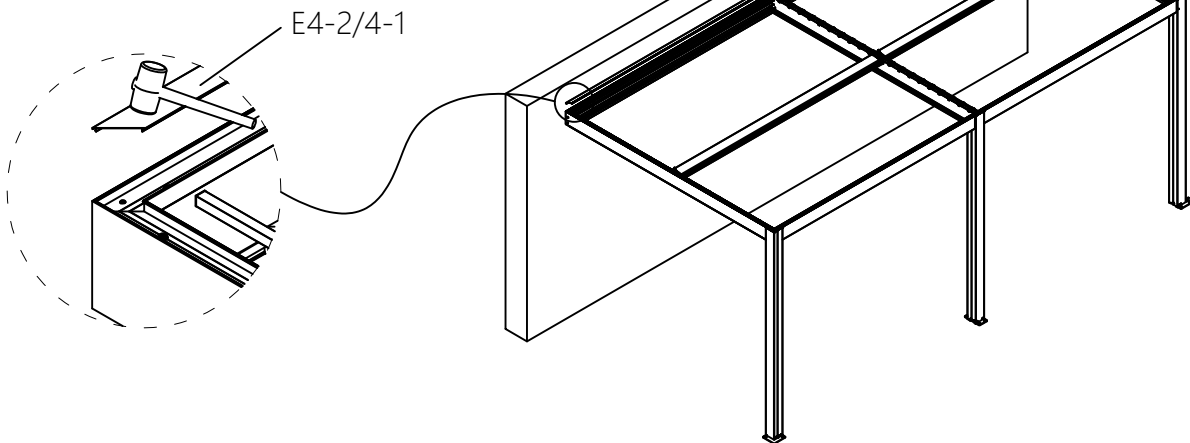

-3、 You should apply silicone sealant on the gap of wall mounted beam

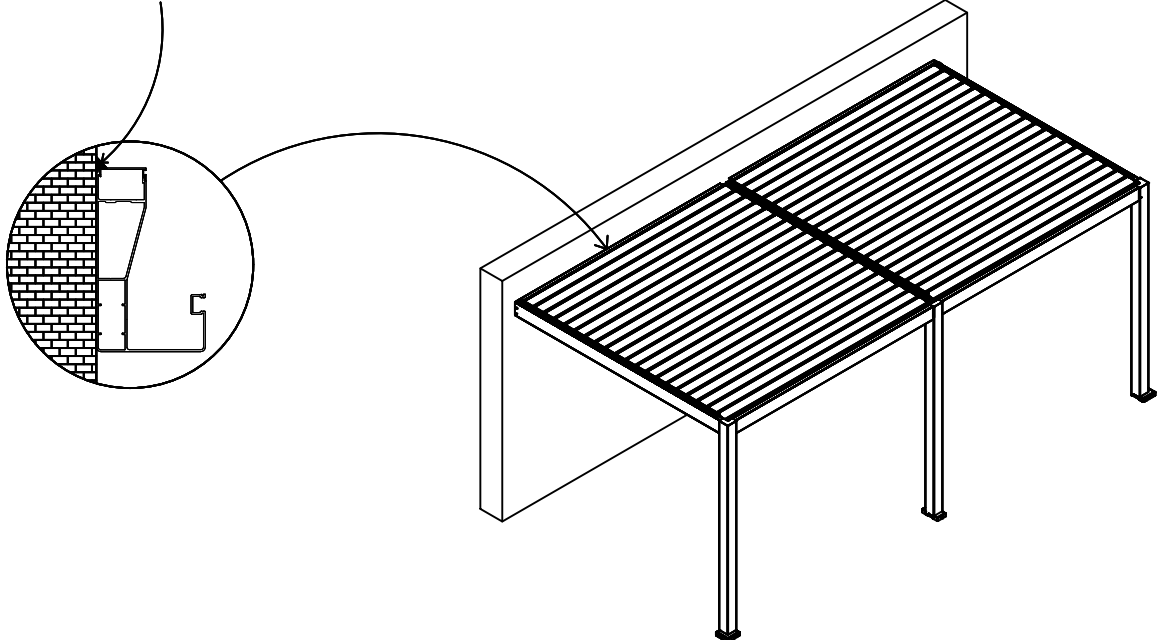

Trouble Shooting

problem	solutions
The motor and lights do not work	<ol style="list-style-type: none">1.Check if the cables is correct2.Check if the voltage for pergola is available: 110V or 220V.3.Check if the remote learn to match the control system.4.Check if the remote is working or not.5.Check if the control system has power output or not.
Blade cannot be opened	<ol style="list-style-type: none">1.Check if the motor works.2.Check if the connection bar is installed correctly.3.Check if the motor connecting blades and the motor are connected properly.
Leakage at the ceiling fan position	<ol style="list-style-type: none">1.Check if the connection do silicone sealant dealing.
The remote does not work	<ol style="list-style-type: none">1.Press the pair button within 5 seconds when the motor input power.2.Check if the remote battery is available.
can not link to APP	<ol style="list-style-type: none">1.ensure you read the manual of tuya app link2.you should remove the previous phone record then you can connect again

Maintenance and Repair

Caring for your pergola

The surface of the product must be cleaned once a year to maintain its original appearance.

The thermosetting powder coating on the product's surface is sensitive to the following:

1. Physical abrasion, hard impacts, extrusion, and chemicals, including alkaline and acidic solvents.
2. Natural elements such as wind, rain, snow, and prolonged exposure to sunlight.

Clean your pergola

1. Do not use a scouring pad, cream cleaner, abrasive sponge, iron wire ball, or colored cloths.
2. Recommended: Soft sponges, soft lint-free cloths, cotton wool, cotton, or non-woven fabrics (white only).
3. Avoid using corrosive products like acidic or alkaline cleaners. It is recommended to wash with water of a lower PH value and then wipe with a cloth to maintain cleanliness.
4. When using high-pressure equipment to clean the structure, take the same precautions: distance, nozzle type, water temperature, and pressure should all be taken into consideration.

Reminder for use

After installation, please check if the screws are tightened and remember to check the screws at least once a year.

1. Regularly check the sealing components to ensure there is no leakage from the seals or other parts.
2. Regularly clean up debris such as fallen leaves on the pergola to prevent blockage of the drainage pipes.
3. Usage limitations: Although the waterproof system is effective, it cannot guarantee complete waterproofness. Heavy rain and strong winds may damage the pergola, and the damage will not be covered by the warranty.

A letter of thanks

Dear Customer,

I would like to take the opportunity to thank you for your patronage and purchasing our products .I assure you have purchased the perfect louvre pergola for you.Our team hopes you love our louvre pergola and share happy time with your family members and friends .

We are a customer-centric company . You are always welcomed to give us feedback ,suggestion and request .Your feedback and comments are very important for us because they help us improve our service.We will be delighted to know what you think about our products. Please feel free to leave reviewson our website or call us directly .

Thanks again and we are pleasure to serve you , if there is anything is not clear to you ,please contact us .

Gratefully